

A guide to the Pipelines Safety Regulations 1996

Guidance on Regulations

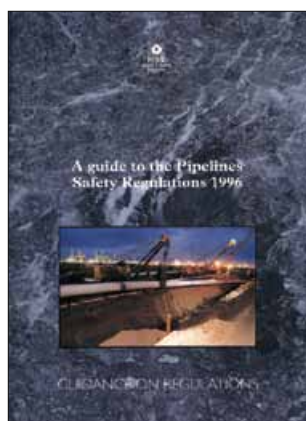

This is a free-to-download, web-friendly version of L82, (First edition, published 1996). This version has been adapted for online use from HSE's current printed version.

You can buy the book at www.hsebooks.co.uk and most good bookshops.

ISBN 978 0 7176 1182 9

Price £9.00

This booklet gives guidance on the Pipelines Safety Regulations 1996 which complement a number of other onshore and offshore regulations.

The Regulations apply to all pipelines in Great Britain and to all pipelines in territorial waters of the UK Continental Shelf, with a few exceptions that are also highlighted in the booklet.

It is aimed at helping operators and others involved with pipeline activities, or those who may be affected by the Regulations, what the Regulations require.

© *Crown copyright 1996*

First published 1996
Reprinted 2002, 2004

ISBN 978 0 7176 1882 9

All rights reserved. No part of this publication may be reproduced, stored in a retrieval system, or transmitted in any form or by any means (electronic, mechanical, photocopying, recording or otherwise) without the prior written permission of the copyright owner.

Applications for reproduction should be made in writing to:
The Office of Public Sector Information, Information Policy Team,
Kew, Richmond, Surrey TW9 4DU or e-mail: licensing@opsi.gov.uk

This guidance is issued by the Health and Safety Executive. Following the guidance is not compulsory and you are free to take other action. But if you do follow the guidance you will normally be doing enough to comply with the law. Health and safety inspectors seek to secure compliance with the law and may refer to this guidance as illustrating good practice.

Contents

Preface 5

Introduction 6

Part I Introduction 7

Regulation 1 Citation and commencement 7

Regulation 2 Interpretation 7

Regulation 3 Meaning of “pipeline” 9

Regulation 4 Application 14

Part II General 15

Regulation 5 Design of a pipeline 15

Regulation 6 Safety systems 16

Regulation 7 Access for examination and maintenance 16

Regulation 8 Materials 17

Regulation 9 Construction and installation 17

Regulation 10 Work on a pipeline 19

Regulation 11 Operation of a pipeline 19

Regulation 12 Arrangements for incidents and emergencies 20

Regulation 13 Maintenance 21

Regulation 14 Decommissioning 22

Regulation 15 Damage to pipeline 23

Regulation 16 Prevention of damage to pipelines 23

Regulation 17 Co-operation 24

Part III Major accident hazard pipelines 25

Regulation 18 Dangerous fluids 25

Regulation 19 Emergency shut-down valves 25

Regulation 20 Notification before construction 26

Regulation 21 Notification before use 28

Regulation 22 Notification in other cases 29

Regulation 23 Major accident prevention document 30

Regulation 24 Emergency procedures 34

Regulation 25 Emergency plans in case of major accidents 35

Regulation 26 Charge by a local authority for a plan 38

Regulation 27 Transitional provision 39

Part IV Miscellaneous 40

Regulation 28 Defence 40

Regulation 29 Certificates of exemption 41

Regulation 30 Repeal of provisions of the Pipe-lines Act 1962 42

Regulation 31 Revocation and modification of instruments 42

Schedule 1	Pipelines to which these Regulations do not apply 43
Schedule 2	Descriptions of dangerous fluids 44
Schedule 3	Requirements for emergency shut-down valves on certain major accident hazard pipelines connected to offshore installations 46
Schedule 4	Particulars to be included in notification relating to construction of a major accident hazard pipeline 48
Schedule 5	Particulars to be notified before certain events relating to major accident hazard pipelines 49
Schedule 6	Revocation and modification 52

Preface

This guide to the Pipelines Safety Regulations 1996 (SI 1996/825) is intended to help pipeline operators and others involved with pipeline activities or who may be affected by the Regulations to understand what the Regulations require.

Environmental considerations

The Pipelines Safety Regulations 1996, made under the Health and Safety at Work etc Act 1974, do not cover the environmental aspects of accidents arising from pipelines. However the Regulations, by ensuring that a pipeline is designed, constructed and operated safely, provide a means of securing pipeline integrity, thereby reducing risks to the environment.

It is important that effects on the environment are considered at all stages in the life cycle of a pipeline.

Most large onshore pipeline projects require an assessment to be carried out which is designed to identify the likely impact of a project on the environment, to determine the significance of that impact and to establish mechanisms which will minimise any adverse impact. The Electricity and Pipeline Works (Assessment of Environmental Effects) Regulations 1990 apply to cross-country pipelines as defined under the Pipelines Act 1962 (PA62) and detail the procedures to be followed when considering the need for an environmental statement to accompany an application for a pipeline construction authorisation from the Secretary of State for Trade and Industry. The Town and Country Planning (Assessment of Environmental Effects) Regulations 1988 apply to PA62 local pipelines.

The Environment Agency (or its Scottish equivalent the Scottish Environment Protection Agency) issues good practice guidance on how the operators' responsibilities under duty of care can best be met. The Water Resources Act 1991 gives the agencies powers of prosecution in the event of any spillages resulting in the pollution of watercourses.

Environmental aspects of offshore pipelines are addressed in the Pipelines Works Authorisations, issued by the Department of Trade and Industry, through the provisions of the Petroleum and Submarine Pipelines Act 1975.

For offshore pipelines with a diameter greater than 800 mm and a length of more than 40 km an environmental impact assessment will soon need to be carried out once the Environmental Impact Directive is implemented.

Information on design and construction

The Health and Safety Commission (HSC) has issued an informal discussion document to consider ways of ensuring that pipeline operators can comply with their duties through the provision of design and construction information.

Introduction

1 This booklet gives guidance on the Pipelines Safety Regulations 1996, which came into force on 11 April 1996. For convenience, the text of each regulation is included in *italics*, with the appropriate guidance immediately below. Where regulations are self-explanatory, no comment is offered.

2 The Pipelines Safety Regulations (referred to as 'the Regulations' in this guidance) replace earlier prescriptive legislation on the management of pipeline safety with a more integrated, goal-setting, risk-based approach encompassing both onshore and offshore pipelines. They revoke various requirements which had become unnecessary.

3 The Regulations complement other onshore and offshore regulations. Offshore they complement the new regime for offshore health and safety legislation at the heart of which lies the Offshore Installations (Safety Case) Regulations 1992 (SI 1992/2885). Onshore they complement the regulations dealing with extending competition to the domestic gas market including the Gas Safety (Management) Regulations 1996 (SI 1996/551). The Pipelines Safety Regulations cover:

- (a) the definition of a pipeline;
- (b) the general duties for all pipelines;
- (c) the need for co-operation among pipeline operators;
- (d) arrangements to prevent damage to pipelines;
- (e) consequential amendments to other regulations (eg repeal of sections of the Pipelines Act 1962 and the revocation of three sets of regulations and parts of three further sets of regulations);

and for major accident hazard pipelines they cover:

- (f) the description of a dangerous fluid;
- (g) the requirement for emergency shut-down valves (ESDVs) at offshore installations;
- (h) the notifications structure;
- (i) the major accident prevention document;
- (j) the arrangements for emergency plans;
- (k) the transitional arrangements.

Scope of the Regulations

4 The Regulations apply to all pipelines in Great Britain, and to all pipelines in territorial waters and the UK Continental Shelf. Schedule 1 lists the pipelines to which these Regulations do not apply. Detailed guidance to Schedule 1 is given in the commentary on the Schedule.

Part I Introduction

Citation and commencement

Regulation

1

Regulation 1

These Regulations may be cited as the Pipelines Safety Regulations 1996 and shall come into force on 11th April 1996.

Interpretation

Regulation

2

Regulation 2

(1) *In these Regulations, unless the context otherwise requires -*

"dangerous fluid" has the meaning given by regulation 18(2);

Guidance

2

5 The definition of dangerous fluid in the Regulations is widely drawn; the fluids covered are contained in Schedule 2 which lists the dangerous fluids by generic category and, where appropriate, the conditions under which they are conveyed.

Regulation 2

"emergency shut-down valve" means a valve which is capable of adequately blocking the flow of fluid within the pipeline at the point at which it is incorporated;

Guidance

2

6 Regulation 19 requires emergency shut-down valves (ESDVs) to be fitted to certain pipelines connected to offshore installations. An ESDV should be capable of stopping the flow of fluid within the pipeline. However, minor internal leakage past the ESDV may be accepted providing it does not represent a threat to safety. The rate of leakage should be based on the installation's ability to control safely the hazards produced by such a leak.

Regulation

2

"the Executive" means the Health and Safety Executive;

"fluid" includes a mixture of fluids;

"local authority" means -

- (a) *in relation to England, a county council, a council having the functions of a county council, the London Fire and Civil Defence Authority, a metropolitan county fire and civil defence authority, or the Council for the Isles of Scilly;*
- (b) *in relation to Scotland, the council for a local government area; and*
- (c) *in relation to Wales, a county council or a county borough council;*

Guidance

2

7 Regulations 25 and 26 relate to emergency plans to be prepared by local authorities. This duty falls to the local emergency planning authority; in the case of metropolitan authorities this rests with the appropriate metropolitan county fire and civil defence authority. In Scotland, where regional councils were replaced by unitary authorities on 1 April 1996, the preparation of emergency plans rests with the local unitary authority.

Regulation 2

“major accident” means death or serious injury involving a dangerous fluid;

Guidance

8 The term ‘major accident’ appears in a number of places in these Regulations. In particular, the judgement whether there is the potential to cause a major accident will determine the range of hazards identified, and the risks to be evaluated, under regulations 23(1)(a) and (b) and will determine the scope of emergency procedures and plans prepared under regulations 24 and 25.

9 A major accident would cover death or serious injury from a fire, explosion or uncontrolled emission from a pipeline. This includes both events which have escalated beyond the control of the normal operating envelope of the pipeline and those resulting from third party interference. Whether an event leads to serious danger to people will depend on factors specific to the incident. Major accidents to people can be distinguished from other accidents by the severity of the injuries, the number of casualties, or by the physical extent of the damage in areas where people may be present. The risk strategy needs to address fully the potential for any major accident.

2

Regulation 2

“major accident hazard pipeline” has the meaning given by regulation 18(1);

Guidance
2

10 A ‘major accident hazard pipeline’ is one which conveys a dangerous fluid which has the potential to cause a major accident.

Regulation

“operator”, in relation to a pipeline means -

- (a) *the person who is to have or (once fluid is conveyed) has control over the conveyance of fluid in the pipeline;*
- (b) *until that person is known (should there be a case where at a material time he is not yet known) the person who is to commission or (where commissioning has started) commissions the design and construction of the pipeline;*
- (c) *when a pipeline is no longer, or is not for the time being used, the person last having control over the conveyance of fluid in it.*

2

Guidance

11 The operator of the pipeline is the person who has control of the pipeline at any time during all stages of its life cycle from the design stage through to final decommissioning.

12 Until the person who is to have control of the conveyance of fluid is known, the operator is the person who commissions the design of the pipeline or (where such work has started) the person who commissioned the design.

2

Regulation

“pipeline” shall be construed in accordance with regulation 3.

(2) Unless the context otherwise requires, any reference in these Regulations to -

- (a) *a numbered regulation or Schedule is a reference to the regulation or Schedule in these Regulations so numbered; and*
- (b) *a numbered paragraph is reference to the paragraph so numbered in the regulation or Schedule in which the reference appears.*

2

Meaning of “pipeline”

Regulation

Regulation 3

(1) Subject to the provisions of this regulation, in these Regulations “pipeline” means a pipe or system of pipes (together with any apparatus and works, of a kind described in paragraph (2), associated with it) for the conveyance of any fluid, not being -

- (a) a drain or sewer;
- (b) a pipe or system of pipes constituting or comprised in apparatus for heating or cooling or for domestic purposes;
- (c) a pipe (not being apparatus described in paragraph (2)(e)) which is used in the control or monitoring of any plant.

(2) The apparatus and works referred to in paragraph (1) are -

- (a) any apparatus for inducing or facilitating the flow of any fluid through, or through a part of, the pipe or system;
- (b) any apparatus for treating or cooling any fluid which is to flow through, or through part of, the pipe or system;
- (c) valves, valve chambers and similar works which are annexed to, or incorporated in the course of, the pipe or system;
- (d) apparatus for supplying energy for the operation of any such apparatus or works as are mentioned in the preceding sub-paragraphs;
- (e) apparatus for the transmission of information for the operation of the pipe or system;
- (f) apparatus for the cathodic protection of the pipe or system; and
- (g) a structure used or to be used solely for the support of a part of the pipe or system.

3

Guidance

13 This regulation defines what is meant by a pipeline. Drains and sewers including liquid effluent outfalls which discharge into a river or estuary are not considered to be pipelines for the purposes of these Regulations.

14 These Regulations do not apply to pipelines which form part of control monitoring equipment such as small bore pipes or tubes normally bundled together with cables, wires, etc to form an ‘umbilical’ used for hydraulic control or signalling purposes.

15 However, new designs of ‘umbilicals’ are appearing with pipes within the bundle which are larger in diameter and are used for the conveyance of fluids for purposes other than control or monitoring. It is likely that future designs may include pipes of considerable diameter or even a number of ‘large’ diameter pipelines bundled together. Even though the basic design and structure of these new systems may be similar to umbilicals, they will be considered to be pipelines and will be subject to the requirements of these Regulations.

16 These Regulations cover pipelines used for the conveyance of fluid. Electrical equipment such as high voltage cable systems which utilise fluid under pressure for circuit integrity and are self-contained are excluded from the scope of these Regulations.

3

Regulation

3

(3) For the purpose of sub-paragraph (c) of paragraph (2) a valve, valve chamber or similar work shall be deemed to be annexed to, or incorporated in the course of, a pipe or system where it connects the pipe or system to plant, an offshore installation, or a well.

Guidance

3

17 Regulation 3(3) defines the interface between plant, an offshore installation or a well and the pipeline.

18 Figures 1 to 7 give examples of different interfaces and illustrate the limits of pipelines covered by these Regulations.

Note: The diagrams in Figures 1 to 7 are for illustrative purposes only - they are not proper representations of actual pipeline systems.

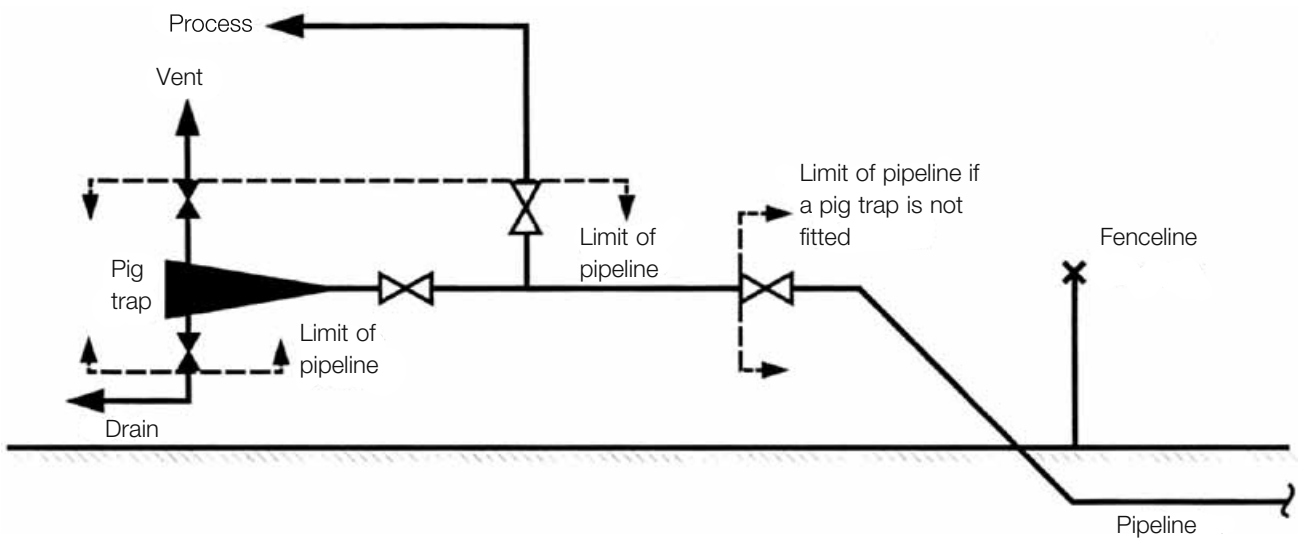

Figure 1 Limit of a pipeline at a factory, onshore terminal, refinery, etc

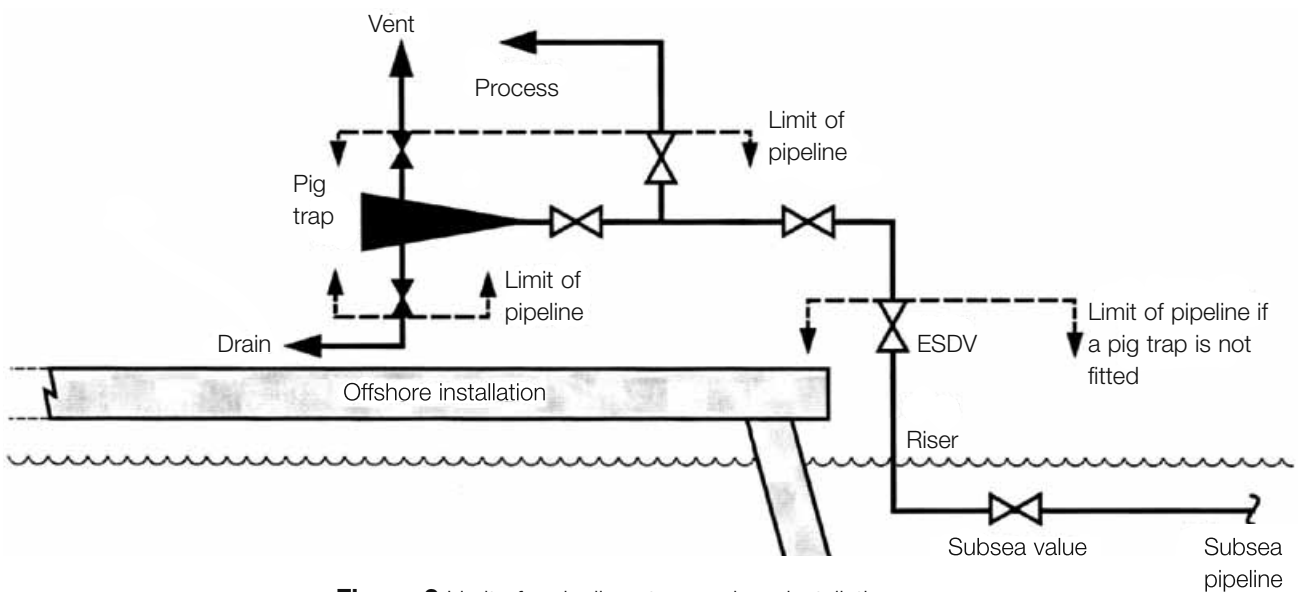

Figure 2 Limit of a pipeline at an onshore installation

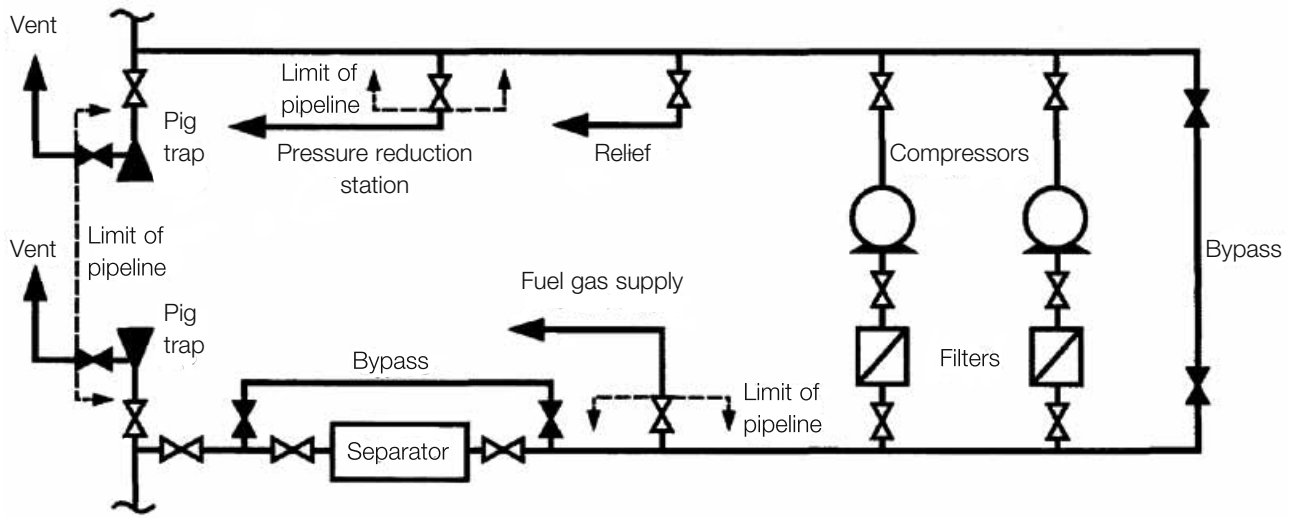

Figure 3 Limit of a pipeline at a mid-line gas compressor station

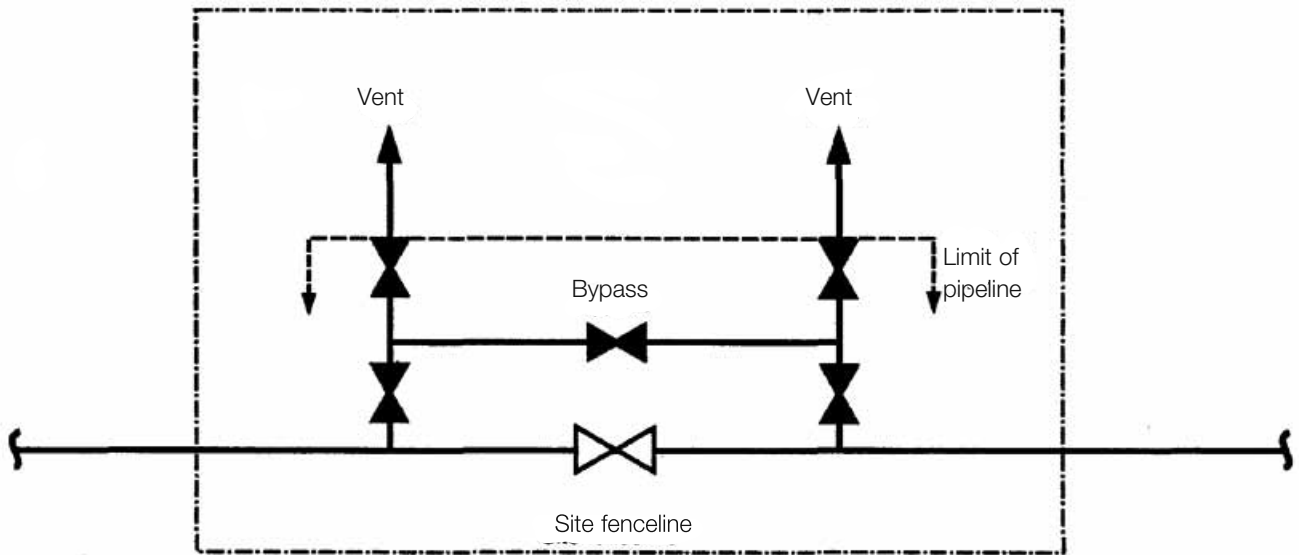

Figure 4 Limit of a pipeline at a block valve site

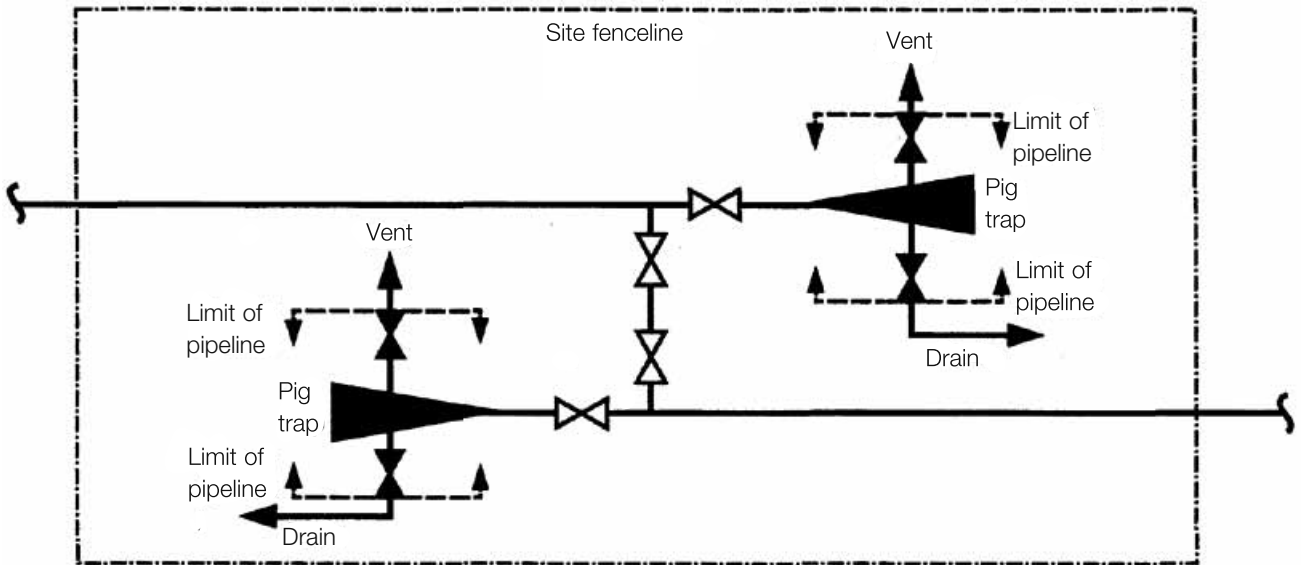

Figure 5 Limit of a pipeline at a mid-point pig trap site

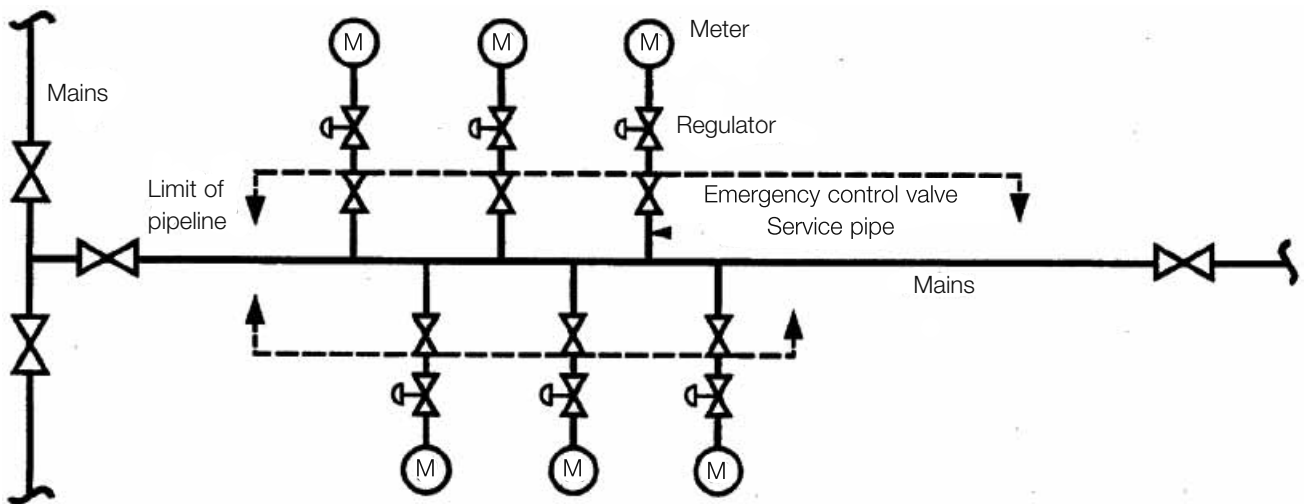

Figure 6 Limit of a pipeline for a gas distribution network

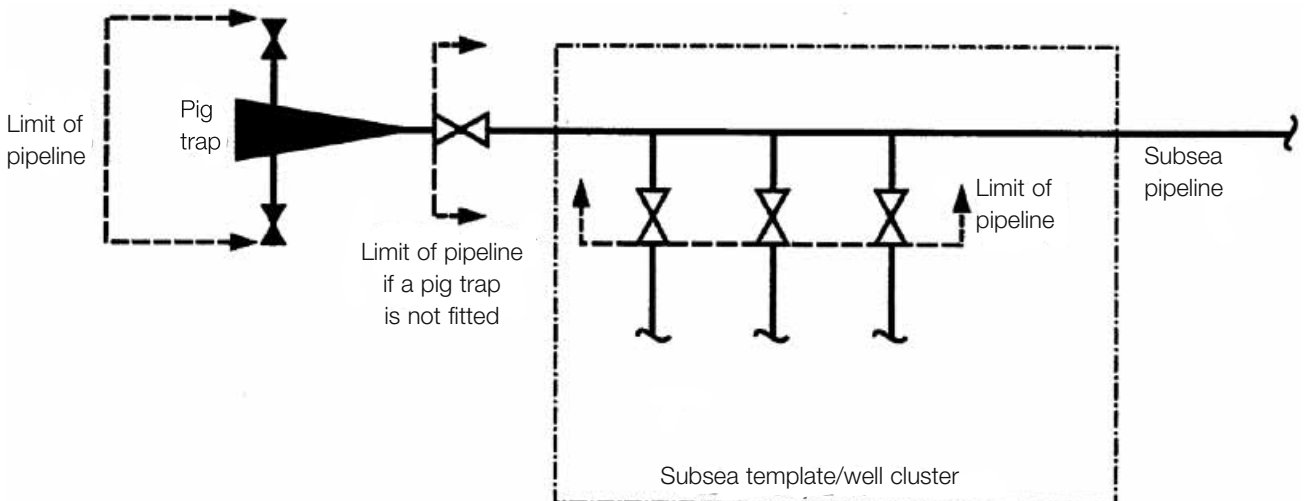

Figure 7 Limit of a pipeline at a subsea template or well cluster

Guidance

3

19 Pig traps connected to a pipeline, used for either launching or receiving pigs or for facilitating other equipment to be run through a pipeline, are included within the scope of the Regulations. The pig itself, or other equipment run through a pipeline, is not considered to be part of the pipeline.

20 For pipelines connected to onshore plant, the limit of the pipeline is the primary shut-off valve which connects the pipeline to the plant or the primary valve(s) off the pig trap, where fitted, which connects the pipeline to the plant. Process plant facilities and pipework beyond the primary shut-off valve are not covered by these Regulations.

21 On an offshore installation the limit of the pipeline is up to and including the emergency shut-down valve or primary shut-off valve(s) off the pig trap, where fitted, which connects the pipeline to the installation.

22 Although apparatus for inducing or facilitating flow is included in the definition of a pipeline, where such apparatus is not incorporated in the pipeline system itself, for example compressors on an offshore installation, then such apparatus is not covered by these Regulations.

Regulation

3

(4) *A pipeline for supplying gas to premises shall be deemed not to include anything downstream of an emergency control.*

(5) *In this regulation -*

“emergency control” means a valve for shutting off the supply of gas in an emergency, being a valve intended for use by a consumer of gas;

“gas” has the same meaning as it has in Part I of the Gas Act 1986^(a).

(a) 1986 c. 44.

Guidance

3

23 For pipelines supplying gas as defined by the Gas Act 1986 to consumers, the limit of the pipeline in these Regulations is the emergency control.

Application

Regulation

4

Regulation 4

(1) Subject to paragraph (2), these Regulations shall apply -

- (a) in Great Britain; and
- (b) to and in relation to pipelines and activities outside Great Britain to which sections 1 to 59 and 80 to 82 of the 1974 Act apply by virtue of article 6 of the Health and Safety at Work etc. Act 1974 (Application outside Great Britain) Order 1995^(b).

(2) These Regulations shall not apply to any pipeline or part of a pipeline which is described in Schedule 1.

(b) SI 1995/263.

Guidance

4

24 This regulation defines the scope of the requirements as pipelines in Great Britain, and all pipelines in territorial waters and the UK Continental Shelf. Schedule 1 lists the pipelines to which these Regulations do not apply. Detailed guidance to Schedule 1 is given in the commentary on the Schedule.

Regulation

4

(3) In the case of a pipeline to which the Pressure Systems and Transportable Gas Containers Regulations 1989^(a) apply, nothing in these Regulations shall require the taking of any measures to the extent that they are for the prevention of danger within the meaning of those Regulations.

(a) SI 1989/2169.

Guidance

4

25 The Pressure Systems and Transportable Gas Container Regulations 1989 (PSTGCR) apply to onshore pipelines which constitute a 'pressure system' where the operating pressure is greater than 3 bar absolute (2 bar gauge) and conveying a relevant fluid. The regulations address in some detail pipeline hazards resulting from the stored energy of the fluid conveyed. Where measures are taken in compliance of PSTGCR to prevent danger within the meaning of those regulations, there will be no requirement for duplication of these measures through the Pipelines Safety Regulations.

Part II General

Design of a pipeline

Regulation

5

Regulation 5

The operator shall ensure that no fluid is conveyed in a pipeline unless it has been so designed that, so far as is reasonably practicable, it can withstand -

- (a) forces arising from its operation;*
- (b) the fluids that may be conveyed in it; and*
- (c) the external forces and the chemical processes to which it may be subjected.*

Guidance

5

26 The purpose of this regulation is to ensure that the design of a pipeline, or any modification to it, takes into account the operating regime for the pipeline, the conditions under which the fluid is to be conveyed as well as the environment to which the pipeline will be subjected.

27 The pipeline, or any modification to it, should be designed so that it is safe within the range of operating conditions to which it could be reasonably subjected. In the pipeline design, account should be taken of the maximum and minimum operating temperatures and of the maximum operating pressure of the pipeline. Account should also be taken of the nature of the fluid being conveyed, for example, corrosive, abrasive or chemical effects. The possibility of any subsequent changes in the fluid to be transported, or in the condition under which it is to be transported should be considered at the design stage.

28 The external forces and the chemical processes to which the pipeline will be subjected will need to be identified and evaluated. Account should be taken of the pipeline location and its susceptibility to damage. This may include consideration of the physical and chemical actions of the environment in which the pipeline is to be located and the terrain, subterrain or sea bed conditions. Account should be taken of foreseeable mechanical and thermal stresses and strains to which the pipeline may be subjected during its operation.

29 It is also important that the forces to which the pipeline is to be subjected during its construction are taken into account in its design.

30 Any change to the fluid conveyed will need a reassessment of the pipeline design to ensure that the pipeline is capable of conveying the fluid safely.

31 The design and location of the pipeline should take account of the hazard potential of the fluid being conveyed. Consideration should be given to routes which will minimise the possibility of external damage. Extra protection may be required to prevent damage from other conditions such as road and river crossings, long self-supported spans and structural movements.

32 In general, British Standards provide a sound basis for the design of pipelines. Other national or international standards (eg a relevant standard or code of practice of a national standards body or equivalent body of any member state of the European Union) are likely to be acceptable provided the proposed standard, code of practice, technical specification or procedure provides equivalent levels of safety.

Guidance

5

33 For low pressure natural gas polyethylene pipelines (operating below 8 bar absolute), technical guidance in the form of recommendations from the Institution of Gas Engineers offers standards recognised across the industry in IGE/TD 3: 1992 Edition 3: *Distribution mains* and IGE/TD 4: 1994 Edition 3: *Gas services*. The design of gas service pipelines is specifically addressed in the HSE Approved Code of Practice and guidance entitled *Design, construction and installation of gas service pipes* (ISBN 0 7176 1172 8).

Safety systems

Regulation

6

Regulation 6

The operator shall ensure that no fluid is conveyed in a pipeline unless it has been provided with such safety systems as are necessary for securing that, so far as is reasonably practicable, persons are protected from risk to their health or safety.

Guidance

6

34 The pipeline should be provided with such safety systems, as necessary, to protect people from risk. Safety systems cover means of protection such as emergency shut-down valves and shut-off valves which operate on demand or fail safe in the closed position, so minimising loss of containment of the pipeline inventory. Safety systems also include devices provided which prevent the safe operating limits being exceeded, for example pressure relief valves.

35 Safety systems are not meant to cover all control or measuring devices. However, safety systems do include control or monitoring equipment, such as flow detectors and pressure monitors, which have to function properly in order to protect the pipeline or to secure its safe operation.

36 Safety systems also include leak detection systems where they are provided to secure the safe operation of the pipeline. The method chosen for leak detection should be appropriate for the fluid conveyed and operating conditions.

37 Interlock arrangements may be provided as safety systems, particularly where they prevent inadvertent operation. For example, valve interlocks may be used in conjunction with bleed devices on pig trap door mechanisms to prevent opening up under pressure.

Access for examination and maintenance

Regulation

7

Regulation 7

The operator shall ensure that no fluid is conveyed in a pipeline unless it has been so designed that, so far as is reasonably practicable, it may be examined and work of maintenance may be carried out safely.

Guidance

7

38 The design of the pipeline should take due account of the need to facilitate examination and maintenance. Consideration should be given at the design stage to any requirement to provide suitable and safe access and operation for in-service inspections, such as pigging.

Materials

Regulation

8

Regulation 8

The operator shall ensure that no fluid is conveyed in a pipeline unless it is composed of materials which are suitable.

Guidance

8

39 This regulation requires that all materials of construction specified in the design of, and in any subsequent modifications to, the pipeline should be suitable for the intended purpose. This requirement applies not only to the pipeline but also to the associated equipment.

40 The material of construction should be able to withstand the physical and chemical conditions of the fluid to be conveyed under the operating conditions for which the pipeline has been designed. Any changes to the fluid conveyed or the operating conditions of the pipeline, including an extension of the pipeline design life, will warrant a reassessment of the pipeline material to ensure it is capable of conveying the fluid safely.

41 Changes in operating conditions include changes to the corrosion protection system which may well affect corrosion rates and therefore the design life of the pipeline.

Construction and installation

Regulation

9

Regulation 9

The operator shall ensure that no fluid is conveyed in a pipeline (save for the purpose of testing it) unless it has been so constructed and installed that, so far as is reasonably practicable, it is sound and fit for the purpose for which it has been designed.

Guidance

9

42 The purpose of this regulation is to ensure that a pipeline which has been properly designed, is fabricated, constructed and installed in a manner to reflect that design. During the installation, design considerations such as the location of the pipeline, depth of cover, need for supports or anchors, and extra protection at vulnerable locations should be adhered to.

43 Suitable procedures should be developed for the construction and installation of the pipeline. Pipe-laying techniques, appropriate to both the location of the pipeline and the type of pipeline being laid should be used.

44 The regulation recognises that before a pipeline is brought into operation it is common to allow the introduction of a fluid, commonly water, into the pipeline to pressure test as part of the demonstration of its soundness and fitness for purpose. Testing in this regulation includes precommissioning work such as pressure testing, flushing or cleaning the pipeline, or other activities which introduce fluids into the pipeline, prior to bringing it into use and the use of intelligent pigs in carrying out a baseline inspection.

Relationship with other Regulations

Onshore Regulations

45 The Construction (Design and Management) Regulations 1994 (CDM) cover the health and safety management of construction projects by those who contribute to the avoidance, reduction and control of health and safety risks faced by construction workers, and others, when engaged on or affected by new construction works. CDM covers the design of the pipeline in so far as the design should take into account the safety of those carrying out the construction (and any subsequent) maintenance work. Similarly, CDM covers the safety management of those involved in the construction during the construction stage, but does not cover the design and construction of the pipeline for safe operation and use. This is covered by the Pipelines Safety Regulations 1996.

46 The CDM Regulations only apply to the actual construction work of a pipeline. Prefabrication work on a pipeline in a fabrication workshop or yard is outside the scope of CDM.

Offshore Regulations

47 Offshore pipelines and pipeline works are subject to the general provisions of the Health and Safety at Work etc Act 1974 (HSW Act) and HSW Act Regulations, such as the Management of Health and Safety at Work Regulations 1992 (MHSWR), which extend outside Great Britain.

48 This legislation is applied offshore by the Health and Safety at Work etc Act 1974 (Application outside Great Britain) Order 1995. The activities covered include: pipe-laying operations and associated work such as trenching; the inspection, testing, maintenance, repair, alteration or renewal of pipelines; and diving operations in connection with such works. MHSWR also extends to the connected activities of loading, unloading, fuelling or provisioning vessels engaged in pipeline works.

49 Employers of workers engaged in pipelines works or connected activities, for example on pipelay barges, are also required under regulation 15(2) of the Offshore Installations and Pipeline Works (Management and Administration) Regulations 1995 to ensure that their workers know or have ready access to the address and telephone number of the HSE office covering the sector in which the pipeline works are taking place.

50 Thus, all occupational risks connected with offshore pipeline construction works are subject to the HSW Act and the associated inspection and enforcement regime.

Work on a pipeline

Regulation

10

Regulation 10

The operator shall ensure that modification, maintenance or other work on a pipeline is carried out in such a way that its soundness and fitness for the purpose for which it has been designed will not be prejudiced.

Guidance

10

51 The purpose of this regulation is to ensure that any subsequent modification, maintenance or other work, such as inspection, of a pipeline should be carried out in such a way as not to affect detrimentally the pipeline's continuing fitness for purpose.

Operation of a pipeline

Regulation

11

Regulation 11

The operator shall ensure that -

- (a) no fluid is conveyed in a pipeline unless the safe operating limits of the pipeline have been established; and*
- (b) a pipeline is not operated beyond its safe operating limits,*

save for the purpose of testing it.

Guidance

11

52 In order to operate the pipeline in a safe manner, the operator will need to draw up safe operating limits, which reflect the pipeline design, its operating history and its current and future condition, and ensure that it is operated and controlled within these limits.

53 For pipelines, safe operating limits may be specified in terms of maximum operating pressure and maximum and minimum temperature. In some cases safe operating limits will also take into account such matters as fluid velocities and any limits set on the composition of the fluid.

54 The regulation recognises that for the purposes of proof testing a pipeline to ensure that it is sound and fit for purpose, it is often necessary to test the pipeline to pressures beyond its maximum allowable operating pressure, the safe operating limit.

Arrangements for incidents and emergencies

Regulation

12

Regulation 12

The operator shall ensure that no fluid is conveyed in a pipeline unless adequate arrangements have been made for dealing with -

- (a) an accidental/ass of fluid from;*
- (b) discovery of a defect in or damage to; or*
- (c) other emergency affecting,*

the pipeline.

Guidance

12

55 This regulation requires that adequate arrangements are in place in the event of an incident or emergency relating to the pipeline. In particular arrangements should be in place for loss of containment and for discovery of damage to, or a defect in, the pipeline which requires immediate attention or action. The detail and scope of the arrangements will vary according to the type of pipeline, its location and the fluid being conveyed. Where a defect in, or damage to, a pipeline is found which could affect the safety of the pipeline, but not requiring immediate attention, then consideration will be needed of appropriate action in such circumstances.

56 In some circumstances it may be necessary for arrangements to be in place for emergencies which may have an affect on the pipeline. For example, arrangements should be in place covering an emergency on an offshore installation which may affect connected pipeline(s).

Relationship with other Regulations

Onshore Regulations

57 In the case of gas pipelines subject to the Gas Safety (Management) Regulations 1996, these arrangements for incidents and emergencies may be referred to in the gas transporter's or network emergency co-ordinator's safety case.

Offshore Regulations

58 Regulation 8 of the Offshore Installations (Prevention of Fire, Explosion and Emergency Response) Regulations 1995 requires the installation operator to draw up an emergency response plan for the installation and this should cover the arrangements in place for emergencies which may affect the connected pipeline.

Maintenance

Regulation

13

Regulation 13

The operator shall ensure that a pipeline is maintained in an efficient state, in efficient working order and in good repair.

Guidance

59 This regulation deals with the requirement to maintain the pipeline to secure its safe operation and to prevent loss of containment. Maintenance is essential to ensure that the pipeline remains in a safe condition and is fit for purpose.

60 The operator needs to consider maintenance and inspection requirements for the pipeline. Examination and monitoring of the pipeline are part of routine maintenance. The operator needs to consider both how and when the pipeline should be surveyed and examined to validate and maintain it in a safe condition.

61 The extent of the work done to maintain a pipeline will depend on its material of construction, its location, the fluid conveyed and the condition under which it is operated. For example, for low pressure gas distribution and service pipelines onshore, the operator should monitor the pipeline to secure its safe operation. For major accident hazard pipelines, the maintenance plan should form part of the pipeline's safety management system.

62 It is important to recognise that a pipeline includes associated equipment such as valves, bridles and other primary attachments. It may also include launch and reception pig traps. These should be maintained, as necessary, to ensure that they are kept in efficient working order. Maintenance under this regulation also includes maintaining any safety system associated with the pipeline which has been provided to secure its safe operation.

63 A pipeline which is out of service should also be maintained in a safe condition; if it has been out of service for a significant period of time, detailed assessment of the condition of the pipeline will be necessary to ensure fitness for purpose before returning it to service.

13

Decommissioning

Regulation

14

Regulation 14

(1) The operator shall ensure that a pipeline which has ceased to be used for the conveyance of any fluid is left in a safe condition.

Guidance

14

64 Pipelines should be decommissioned in a manner so as not to become a source of danger. Once a pipeline has come to the end of its useful life, it should be either dismantled and removed or left in a safe condition. Consideration should be given to the physical separation and isolation of the pipeline. It may be necessary to purge or clean the pipeline; due consideration should be given to the hazardous properties of any fluid conveyed in the pipeline or introduced during the decommissioning.

65 Depending on the physical dimensions of an onshore pipeline and its location, under the general provisions of the HSW Act, it may be necessary to consider the risk of the pipeline corroding and causing subsidence or acting as a channel for water or gases.

66 Offshore, pipelines should be either dismantled and removed or left in a condition where they will not become a source of danger to people. It is likely that the riser section of an offshore pipeline will be dismantled. However, the extent of the obligation to remove the remainder of the pipeline will depend on the diameter of the pipeline, its location on the sea bed, its stability and on subsea conditions. It should be noted in this context that the decommissioning (in statutory language, abandonment) of offshore pipelines is also subject to and regulated by the Petroleum Act 1987 and should be discussed with the Department of Trade and Industry, whose formal approval for decommissioning programmes is required before they can be implemented.

Regulation 14

(2) The operator of pipeline shall ensure that work done in discharge of the duty contained in paragraph (1) is performed safely.

Guidance 14

67 Work done in carrying out the final decommissioning of a pipeline should be done in a safe and controlled manner.

Damage to pipeline

Regulation

15

Regulation 15

No person shall cause such damage to a pipeline as may give rise to a danger to persons.

Guidance

15

68 This regulation applies to the operator of the pipeline, for example when carrying out maintenance on the pipeline, to ensure that the pipeline does not sustain damage through his actions which could give rise to danger to people. Equally this regulation applies to the actions of third parties since interference is the main cause of damage to pipelines leading to loss of containment.

69 In many cases the damage to a pipeline by a third party is accidental; it is important that such damage is reported to the pipeline operator. Failure to notify damage to a pipeline which ultimately affects the safety of others could be a breach of the HSW Act. Some third party incidents may not appear to have caused obvious or serious damage, however, these incidents should still be reported to the pipeline operator as the pipeline may have been weakened or its integrity impaired in some other way, eg damage to its corrosion protection coating.

70 It is important that the location of onshore pipelines, and in particular underground pipelines, is considered when carrying out building, excavation or dumping or other such work, as such activities may either cause damage to pipelines or deny access to them for maintenance purposes.

71 Similarly, when carrying out vessel or anchoring activities offshore the location of offshore pipelines should be considered. Information regarding the location of offshore pipelines is normally available from the Hydrographer of the Navy and included on Admiralty charts.

Prevention of damage to pipelines

Regulation

16

Regulation 16

For the purpose of ensuring that no damage is caused to a pipeline, the operator shall take such steps to inform persons of its existence and whereabouts as are reasonable.

Guidance

16

72 It is important that third parties are made aware of the presence of a pipeline, and that information is available, where appropriate, regarding the location of the pipeline. For instance, where street work is to be undertaken information on the location of underground services including pipelines will be required. On request, pipeline operators should be able to give approximate locations of pipelines, usually in the form of plans.

Guidance

73 Because of the problems associated with identification of underground pipelines, parallel running of similar pipelines in the street should be avoided; where it is unavoidable, consideration should be given to means of identifying each pipeline such as with coloured plastic marker tape or indicator tape incorporating a metallic tracer wire. A colour coded identification system used by utilities and local authorities is set out in the National Joint Utilities Group publication No 4 *The identification of small buried mains and services* April 1995.

74 The operator shall take reasonable steps to inform people of the existence of the pipeline and its whereabouts, and for major accident hazard pipelines there should be regular contact with owners/occupiers and tenants of the land through which the pipeline passes. This should include supplying information on the route of the pipeline.

75 Depending on the fluid conveyed, the pipeline location and the conditions under which it is conveyed, it may be appropriate to consider periodic surveying of its route to check on activities which might affect the pipeline.

76 Offshore, damage to pipelines may arise from fishing activities and anchoring. Consideration should be given to reducing the potential for damage to offshore pipelines by use of concrete coating, trenching, burial, protection structures or mattresses etc.

Relationship with other Regulations

77 As part of the offshore Pipeline Works Authorisation issued by the Department of Trade and Industry under the Petroleum and Submarine Pipelines Act 1975, information regarding the location of offshore pipelines is normally passed to the Hydrographer of the Navy for inclusion on Admiralty charts.

16

Co-operation

Regulation

17

Regulation 17

Where there are different operators for different parts of a pipeline, each operator shall co-operate with the other so far as is necessary to enable the operators to comply with the requirements of these Regulations.

Guidance

17

78 This regulation places a duty on operators of different parts of a pipeline or a pipeline system to co-operate with other operators of that pipeline or system, where appropriate, to enable each of them to fulfil their duties under these Regulations. It does not mean that an operator of part of a pipeline can evade his own responsibilities by seeking to pass them to others. If an operator is capable of complying with a duty unaided, then the co-operation duty does not come into play. However, it is likely that where a pipeline or pipeline system has different operators for different parts of it, co-operation between each operator will be required in ensuring the health and safety of people or activities involving the pipeline.

Part III Major accident hazard pipelines

Dangerous fluids

Regulation 18

Regulation 18

(1) *The provisions contained in regulations 19 to 27 shall apply in relation to a pipeline in which a dangerous fluid is being, or is to be conveyed (in these Regulations referred to as a “major accident hazard pipeline”).*

Guidance 18

79 This regulation defines the pipelines with the potential to cause a major hazard accident which attract the additional duties under these Regulations: emergency shut-down valves, notifications, the preparation of a major accident prevention document, the preparation of emergency procedures and the preparation of an emergency plan by the local authority.

Regulation 18

(2) *For the purpose of these Regulations a fluid is a dangerous fluid if it falls within a description in Schedule 2.*

Guidance 18

80 Dangerous fluids which are brought within these requirements are listed in Schedule 2. Detailed guidance about which fluids are described as dangerous is given in the commentary on the Schedule.

Emergency shut-down valves

Regulation 19

Regulation 19

- (1) *The operator of a major accident hazard pipeline which -*
- (a) *is connected to an offshore installation; and*
 - (b) *has an internal diameter of 40 millimetres or more,*

shall ensure that the requirements contained in Schedule 3 are complied with in relation to the pipeline.

Guidance 19

81 Emergency shut-down valves (ESDVs) are required to be fitted to all risers of major accident hazard pipelines of 40 mm or more in diameter at offshore installations. Schedule 3 sets out the requirements for these ESDVs.

Regulation 19

(2) *The duty holder in relation to an offshore installation to which a pipeline described in paragraph (1) is connected shall afford, or cause to be afforded, to the operator of the pipeline such facilities as he may reasonably require for the purpose of securing that the requirements contained in Schedule 3 are complied with in relation to the pipeline.*

- (3) *In this regulation -*

“duty holder”, in relation to an offshore installation, means the person who is the duty holder as defined by regulation 2(1) of the 1995 Regulations in relation to that installation.

Regulation

19

“the 1995 Regulations” means the Offshore Installations and Pipeline Works Management and Administration) Regulations 1995^(a).

(a) SI 1995/738.

Guidance

19

82 This regulation places a duty on the duty holder in relation to the offshore installation to provide the operator of the pipeline with such facilities as he requires to fulfil his duties as set out in Schedule 3.

Notification before construction

Regulation

20

Regulation 20

The operator shall ensure that the construction of a major accident hazard pipeline is not commenced unless he has notified to the Executive the particulars specified in Schedule 4 at least 6 months, or such shorter time as the Executive may approve, before such commencement.

Guidance

20

83 This regulation requires the operator to notify HSE of certain details of a proposed new pipeline prior to its construction. The intention is that this notification should be made at the ‘end of the concept design’ stage, which will normally be at least 6 months prior to the start of construction. The notification must contain the information contained in Schedule 4. This regulation only requires a notification to HSE; this does not place any constraint on the operator to proceed to detailed design and construction.

84 This notification may form the first contact between the pipeline operator and HSE; earlier contact may be helpful. This notification should be made at a point where the design is sufficiently advanced to be able to set out, in general terms, the particulars required in Schedule 4 but not so late that the company has already committed itself to major expenditure. Once a pipeline has been built, it is very difficult and extremely costly to make changes.

85 Only a limited amount of information about the pipeline is required at this notification stage. Where some of the information cannot, at the time of notification, be fully specified, notification to HSE should go ahead, together with details of when the further information may be provided, by agreement between the operator and HSE.

86 This notification is aimed at triggering HSE’s inspection arrangements and it will provide the basis for the start of a dialogue between the pipeline operator and HSE about arrangements to secure the proper construction and safe operation of the pipeline. The intention behind the notification is to ensure that HSE is made aware of the proposed pipeline before major expenditure has been committed, since it is at this early stage that the most recent and best practice of design, and use of materials, can be applied at least cost. The information that is supplied will help HSE to form a view on appropriate inspection arrangements.

87 The information to be supplied need only represent the particulars as far as they have been developed by this stage. It is likely that there may be minor changes to the information, however, where the changes are significant to the level of risk of the pipeline, these further details should be supplied to HSE.

Guidance

88 Although for major projects, this notification will be made at an early stage and at least 6 months prior to the start of construction, there may be cases when a shorter notification period will be appropriate. HSE will be sympathetic to requests for shorter notification periods where good reason is demonstrated.

89 This may apply offshore to shorter lengths of pipeline or small projects, such as pipeline network extensions. There will also be cases which are a result of operational demands such as where there is a requirement to construct a pipeline from an installation for the purposes of well testing or evaluation. Cases when shorter notification is appropriate need the approval of HSE.

90 A reduced period of notification may be approved for short onshore pipelines, eg local pipelines to be built under section 2 of the Pipelines Act 1962, which may be viewed as relatively small projects where construction may be required to start over a shorter scale than six months.

91 Notification shall contain the details listed in Schedule 4. Notification should be sent to the appropriate office of HSE's Chemical and Hazardous Installations Division (CHID) in Aberdeen or Norwich (addresses below). As a general guide, pipelines located in Scotland or in Scottish waters are covered by the Aberdeen office, all other pipelines are covered by the Norwich office. Fax or other electronic transmission arrangements are acceptable.

Health and Safety Executive (CHID)
Lord Cullen House
Fraser Place
Aberdeen AB25 3UB
Tel: 01224 252500
Fax: 01224252555

Health and Safety Executive (CHID)
122A Thorpe Road
Norwich
Norfolk NR1 1RN
Tel: 01603 275000
Fax: 01603 275055

Relationship with other Regulations

92 This notification does not form part of the role HSE undertakes as a consultee on the route of the pipeline for planning purposes. However, since HSE is consulted on, and assesses the route of, major accident hazard pipelines, both onshore and offshore, in practice the information required in the notification under this regulation will also be required for HSE to assess the route as a consultee.

Onshore pipelines

93 HSE is a consultee on the route of a land pipeline attracting the additional duties. The Department of Trade and Industry consults HSE on the route of cross-country pipelines and local planning authorities consult HSE on the route of local pipelines under the Pipelines Act 1962.

94 Through the licence condition of a public gas transporter under the Gas Act 1995, the route of high pressure gas pipelines need to be notified to HSE. In cases where the route does not comply with specific guidelines, HSE should be consulted on the proposed route.

Offshore pipelines

95 HSE is a consultee of the Department of Trade and Industry on the route of a proposed new pipeline under the Petroleum and Submarine Pipelines Act 1975.

Notification before use

Regulation

21

Regulation 21

The operator shall ensure that no fluid is conveyed in a major accident hazard pipeline, or conveyed following a period in which it has been out of commission (other than for routine maintenance), until the expiration of 14 days, or of such shorter period as the Executive may in that case approve, from the receipt by it of a notification of the date on which it is intended to convey, as the case may be, resume the conveyance of fluid in the pipeline.

Guidance

21

96 This notification, of the intention to bring the pipeline into use, is required so that HSE is made aware that the dangerous fluid is to be introduced into the pipeline.

97 A notification period of 14 days is required; though in exceptional circumstances a shorter notification period may be permissible if agreed by HSE.

98 This notification applies to the first introduction of the dangerous fluid into the pipeline. However, this regulation also applies to circumstances where the pipeline may have been taken out of commission (other than for routine maintenance, planned or emergency repair) and is to be brought back into use.

99 It is not intended that notification of bringing back into use will be required after it has been shut down for routine maintenance. Routine maintenance includes work such as valve lubrication, maintenance of pig traps, maintenance and replacement of cathodic protection equipment, function testing of pipeline equipment and instrumentation, running repair work (slight surface damage repairs, coating and wrapping repairs, rectification of spans etc). However, in cases where the pipeline has been subject to major modifications or remedial work which has been notified to HSE under regulation 22, notification of bringing back into use is required.

100 Notification can be made in writing, by fax or by telephone to the appropriate office of HSE's Chemical and Hazardous Installations Division (CHID) in Aberdeen or Norwich. Other electronic transmission arrangements are also acceptable. Information should include the pipeline identification, name of the operator/point of contact and date the pipeline is to be used for the first time or reused.

Notification in other cases

Regulation 22

Regulation

(1) *Where there is a change of operator of a major accident hazard pipeline, or of his address, the operator shall notify any such change to the Executive within 14 days thereafter.*

(2) *Subject to paragraph (3), in the case of a major accident hazard pipeline the construction of which has commenced, or has been completed, the operator shall ensure that no event of a kind described in Schedule 5 takes place until the expiration of 3 months, or such shorter time as the Executive may in that case approve, from the receipt by the Executive of particulars specified in that Schedule in relation to such event.*

(3) *Where an event of a kind described in Schedule 5 takes place in an emergency, the operator shall notify to the Executive the particulars specified in that Schedule as soon as is reasonably practicable.*

22

Guidance

101 This regulation concerns any significant changes to the pipeline which affect the level of risk. Notification to HSE is required of certain changes such as changes in the operating regime, major modifications to the pipeline, changes in fluid and cessation of use of the pipeline.

102 Schedule 5 sets out instances when notification is required; detailed guidance is given in the commentary to the Schedule.

103 The notification should be made to HSE at completion of the concept design for the change. The intention behind the 3-month notification period is to ensure that HSE is made aware of the proposed changes to a pipeline once the details have been established but before major expenditure has been committed. The information that is supplied will help HSE to form a view on appropriate inspection arrangements. However, urgent works may be carried out with shorter notification periods with the approval of HSE.

104 Notification of change of the pipeline operator, or his address, should be made within 14 days of the change being known.

105 Notification should be sent to the appropriate office of HSE's Chemical and Hazardous Installations Division (CHID) in Aberdeen or Norwich. Notification in writing, by fax or other electronic transmission arrangements is acceptable.

22

Major accident prevention document

Regulation

Regulation 23

(1) *The operator shall, before the design of a major accident hazard pipeline is completed prepare, and thereafter revise or replace as often as may be appropriate, a document relating to the pipeline containing, subject to paragraph (2) sufficient particulars to demonstrate that -*

- (a) *all hazards relating to the pipeline with the potential to cause a major accident have been identified;*
- (b) *the risks arising from those hazards have been evaluated;*
- (c) *the safety management system is adequate; and*
- (d) *he has established adequate arrangements for audit and for the making of reports thereof.*

(2) *Paragraph (1) shall only require the particulars in the document referred to in paragraph (1) to demonstrate the matters referred to in that paragraph to the extent that it is reasonable to expect the operator to address them at the time the document is prepared or revised.*

(3) *Where the document referred to in paragraph (1) describes any health and safety arrangements or procedures to be followed, the operator shall ensure that those arrangements or procedures are followed unless in particular circumstances of the case it is not in the best interests of the health and safety of persons to follow them, and there has been insufficient time to revise or replace the document to take account of those circumstances.*

(4) *In this regulation -*

“audit” means systematic assessment of the adequacy of the safety management system, carried out by persons who are sufficiently independent (if the system (but who may be employed by the operator) to ensure that such assessment is objective; and

“safety management system” means the organisation, arrangements and procedures established by the operator for ensuring that the risk of a major accident is as low as is reasonably practicable.

23

Guidance

106 This regulation deals with the operator's overall aims and principles of action for the control of the aspects of design, construction and installation, operation, maintenance and final decommissioning which have a bearing on the health and safety arrangements with respect to the control of major accident hazards.

107 The major accident prevention document (MAPD) initially shall be prepared during the design of the pipeline. Where there is a change in the fluid conveyed which results in an existing non-major accident hazard pipeline falling within the definition of a major accident hazard pipeline, then this will require a reassessment of the pipeline design. The MAPD should be prepared at this reassessment stage.

23

Guidance

Major accident prevention document

108 The MAPD is a management tool to ensure that the operator has assessed the risk from major accidents and has introduced an appropriate safety management system to control those risks. The aim is that the document will explain how the operator has established satisfactory management systems to control the major accident hazards of the pipeline or pipeline system.

109 The MAPD can be made up of a number of documents. A covering document may be prepared which need only be a short statement setting out the health and safety arrangements with respect to the control of the major accident hazards. This covering document should, however, refer to more detailed documents which make up the MAPD. These will include the safety management system detailing arrangements such as training procedures, management responsibilities and auditing arrangements which set down how that operator's policy to control major accident hazards will be put into action. It is important to recognise that safety management is an integral part of the normal business management of an organisation.

110 The MAPD should contain sufficient information to demonstrate that all hazards relating to the pipeline with the potential to cause a major accident have been identified and the risks arising from those hazards have been evaluated.

111 This requires the operator to identify the ways in which a major accident may occur and to evaluate the risks arising from those hazards. Account will need to be taken of hazards during the various stages of the life cycle of the pipeline including commissioning, excursions from normal operating limits, maintenance and any other activity which may affect the pipeline. This also requires consideration of matters such as the nature of the dangerous fluid being conveyed, the conditions under which it is conveyed and the susceptibility of the pipeline system to damage.

112 Where appropriate, an operator can produce a single MAPD for all his pipeline systems, rather than produce a separate MAPD for each individual pipeline. The MAPD must reflect the hazards and risks associated with all the major accident hazard pipelines covered by it and the supporting safety management system should be applicable to all those pipelines.

Safety management system

113 The pipeline MAPD should be supported by the safety management system which is in place for the control of the safety of the pipeline throughout its life cycle from its concept design through to decommissioning. The safety management system will need to consider the interfaces between the pipeline design, construction, operation and maintenance. Key elements of safety management are management's leadership, commitment and accountability. Both an adequate organisation and sufficient resources are necessary to implement the operator's policy with respect to the control of major accident hazards effectively.

114 It will be necessary for the MAPD, and the associated management arrangements, to be updated at various stages throughout the life cycle of the pipeline. It is recognised that, for example, at the concept design stage, it may not be practicable to describe future management procedures for controlling risks to people during the operation of the pipeline.

Guidance

115 A clear line of responsibility and accountability for the control of health and safety needs to be established from the highest management down. As a pipeline moves through the various stages of its life cycle, the line of command and accountability might change; the basis for change and arrangements for bringing it about should be set out in the safety management system.

116 The safety management system should cover the organisation and arrangements for preventing, controlling and mitigating the consequences of major accidents. These include specific attention to management competencies and procedures necessary to minimise the possibility of these events and if they occur, to limit their potential for causing harm. The safety management system is likely to set out the management control and monitoring procedures to be followed in critical areas such as:

- ensuring that systems are in place to provide for the satisfactory co-ordination of all those involved in the safety of the pipeline;
- establishment of operating procedures for normal operation of the pipeline as well as abnormal operation and non-routine operations;
- communication of those procedures to relevant personnel, eg through instructions, operating manuals, permits to work;
- establishment of adequate systems for the selection, control and monitoring the performance of contractors so that their working methods and standards are such as to ensure the safety of their activities;
- establishment of standards for training, for all people with a significant role to play in the safety of the pipeline. This is likely to extend to the highest levels of management and will also deal with training of those in supporting roles such as engineers and contractors;
- the procedures adopted for the systematic appraisal of the major accident hazards associated with the pipeline and evaluation of the risks arising from those hazards;
- procedures for the planning of modifications to be made to the pipeline.

117 The importance of the arrangements for achieving the initial and continuing safety of the pipeline requires that the safety management system pay particular attention to these arrangements. These include the arrangements for ensuring the soundness and fitness for purpose at the various stages in the life cycle of the pipeline.

118 It will be necessary that suitable and sufficient records of a pipeline are kept, including the design, construction, operation, and maintenance, so as to be able to demonstrate that the pipeline is safe.

119 Specific arrangements for dealing with emergencies form part of the safety management system. The emergencies to be addressed will result from the hazard identification and risk assessment process. Having identified all types of emergency events, plans and procedures should be prepared for dealing with these. The preparation of emergency procedures is covered in regulation 24.

Guidance

Audit

120 Once a systematic and formalised management approach to safety has been implemented, it becomes necessary to audit the system performance. This regulation requires that arrangements are in place for audits to be made of the safety management system which address its adequacy in achieving the safety of the pipeline. This requires a demonstration that there are clearly defined systems for audit of the quality of the design, construction, operation, maintenance and finally decommissioning of the pipeline. As for other aspects of the safety management system, performance standards for the audit and review process should be set and monitored. The people carrying out the audits should be sufficiently independent to ensure that such an audit is objective.

121 Auditing is referred to in HSE's publication *Successful health and safety management* as 'the structured process of collecting independent information on the efficiency, effectiveness and reliability of the total safety management system and drawing up plans for corrective action'.

122 In order to provide the necessary independent perspective and to maximise the benefits from the auditing process, audits should be carried out by competent people outside the line management chain of the areas or activities being audited.

123 Performance standards should be established to identify responsibilities, timings, and systems for reviewing. To ensure effectiveness, those responsible for implementing any remedial action should be clearly identified and deadlines set for the completion of such action. Audit should be viewed by all within the organisation as an opportunity to identify weaknesses in management control or procedures.

Relationship with other Regulations

Offshore Regulations

124 The definition in the Offshore Installations and Pipeline Works (Management and Administration) Regulations 1995 excludes pipelines, nevertheless there is a provision for any part of a pipeline connected to an installation and within 500 metres of the installation to be 'deemed' to be part of that installation, which is appropriate when considering the safety of people on the installation and possible consequences of a pipeline failure.

125 For the same reasons, offshore pipelines fall partly within the scope of the offshore safety case regime. Under Schedules 1 and 2 of the Offshore Installations (Safety Case) Regulations 1992 (SCR), the safety case must demonstrate that full account has been taken of risks to the installation, and to the people on it, arising from the pipeline. This entails, for any pipeline connected to an installation, giving a description of the design and hydrocarbon inventory of the pipeline demonstrating that an integrated approach will be taken to the management of the installation and the pipeline so risks from a major accident are at the lowest level that is reasonably practicable. The SCR provisions regarding pipelines at the interface are not enough in themselves to ensure the safe operation and integrity of offshore pipeline systems as a whole. However, work done in the safety case to identify the safety critical elements of a pipeline can be used in the pipeline MAPD.

Guidance

Onshore Regulations

126 The Gas Safety (Management) Regulations 1996 (GS(M)R) are concerned essentially with the safe management of the flow of gas through public gas transporters' networks. Those Regulations require a safety case to be prepared which should contain sufficient information to demonstrate that the transporter's operation is safe, and that the risks to the public and employees are as low as is reasonably practicable. Schedule 1 of those Regulations lists the particulars to be included in the safety case. It is not intended that the requirements of Schedule 1 of GS(M)R should duplicate those in the Pipelines Safety Regulations 1996 (PSR).

127 There are some areas of unavoidable overlap between these two sets of regulations, in particular the duties dealing with safety management systems (the MAPD in PSR and the safety case in GS(M)R). Although PSR covers safety management systems, such systems are concerned solely with pipeline integrity and the consequences of its loss. In contrast GS(M)R is concerned with the safe management of the supply of gas to users and the management of the flow of gas. To minimise duplication, those parts of any documents which are prepared under the requirements in PSR can be referenced in the GS(M)R safety case.

23

Emergency procedures

Regulation

Regulation 24

(1) The operator shall ensure that no fluid is conveyed in a major accident hazard pipeline unless -

- (a) such appropriate organisation and arrangements as shall have effect; and*
- (b) the procedures which shall be followed in different circumstances,*

in the event of an emergency relating to the pipeline have been established and recorded.

(2) The operator shall revise or replace the record of the organisation, arrangements and procedures referred to in paragraph (1) as often as may be appropriate.

(3) The operator shall ensure that the organisation, arrangements and procedures referred to in paragraph (1) are tested, by practice or otherwise, as often as may be appropriate.

24

Guidance

128 This regulation requires that adequate emergency procedures are prepared for dealing with the consequences of a major accident involving a pipeline. The detail and scope of a major accident will vary according to the pipeline, its location and the fluid conveyed and the operator will need to consider these aspects when drawing up the emergency procedures.

129 The emergency procedures for an offshore pipeline should cover the pipeline, as an entity, as well as the interface with offshore and onshore installations. The plan should cover the procedures needed to respond to all foreseeable major accidents involving a pipeline, ie it should set out who does what, when and how and to what effect, in the event of an emergency. It should describe arrangements at the interfaces with onshore and offshore installations to ensure that they dovetail.

24

Guidance

130 For onshore pipelines, it is important that the pipeline operator and local authorities liaise to ensure that the emergency procedures and the local authorities' emergency plans are dovetailed in order to provide a comprehensive and effective response to emergencies.

131 The emergency procedures should be kept in an up-to-date operational state. They should be revised as necessary to ensure that they cater for any changes in operation that might have a significant effect on the procedures.

132 Although this regulation does not specify the frequency at which tests should be carried out, it is important that the procedures are exercised and tested with sufficient frequency and depth so that they can be relied upon to work effectively in an emergency. The procedures should be monitored and reviewed in the light of exercises and tests and of any practical experiences gained from operating the plan in a real emergency, and remedial action identified and taken.

Relationship with other Regulations

Offshore Regulations

133 Regulation 8 of the Offshore Installations (Prevention of Fire and Explosion, and Emergency Response) Regulations 1995 (PFEER) requires the owner or operator of an installation to prepare an emergency response plan for the installation after consulting with people likely to become involved in emergency response. Consultees will include the pipeline operator, operators and owners of other installations as necessary, for the plan to reflect agreement about shutting down pipelines for emergency response. The relevant parts of the pipeline emergency procedures required by the Pipelines Safety Regulations 1996 and the emergency response plan prepared through the requirement in PFEER should be compatible.

24

Emergency plans in case of major accidents

Regulation

Regulation 25

(1) *A local authority which has been notified by the Executive that there is, or is to be a major accident hazard pipeline in its area shall before the pipeline is first used or within 9 months of such notification, whichever is later, and subject to paragraph (5), prepare an adequate plan detailing how an emergency relating to a possible major accident in its area will be dealt with.*

(2) *In preparing the plan pursuant to paragraph (1) a local authority shall consult the operator of the pipeline, the Executive and any other persons as appear to the authority to be appropriate.*

(3) *A local authority which has prepared a plan pursuant to paragraph (1) shall, as often as is appropriate and, in any case, at least every three years review the plan and make such revision as is appropriate.*

25

Regulation

(4) *The operator of a major accident hazard pipeline shall ensure that every local authority through whose area the pipeline will pass is furnished promptly with such information as it may reasonably require in preparing the plan referred to in paragraph (1).*

(5) *It shall be deemed to be sufficient compliance with the requirement in paragraph (1) as to the time by which a plan is to be prepared, where such time is exceeded by reason of waiting for information referred to in paragraph (4) which has been promptly required.*

(6) *Where a pipeline passes or is to pass through the areas of two or more local authorities the duties under this regulation may be discharged by them where they prepare a single plan.*

25

Guidance

134 Local authorities at county or equivalent level, once notified of a pipeline by HSE, are required by this regulation to prepare an emergency plan for each major accident hazard pipeline passing through their area. The requirement under these Regulations is for emergency plans which should specifically relate to the protection of the health and safety of people, not environmental damage.

135 Though local authorities will already have general emergency plans, it will be necessary to have either pipeline specific plans or to include specific reference to each major accident pipeline and how their emergency arrangements are integrated into the existing emergency provisions in the area covered by the authority.

136 It is intended that emergency plans should only be drawn up or amended after consultation with bodies who may be able to contribute information or advice. In all cases this will include the emergency services (fire, police and ambulance), hospitals, the pipeline operators and HSE. Other bodies to be consulted will depend on circumstances and could include adjacent local authorities through whose area the pipeline passes, government departments dealing with agriculture, the Environment Agency or its Scottish equivalent, the Scottish Environment Protection Agency, and companies providing water services.

137 Full liaison and effective two-way flow of information is required between the pipeline operator and the local authority. Information from the pipeline operator is needed to enable the authority to draw up the emergency plan, and information from the authority should be available to the pipeline operator to assist in the preparation of the pipeline emergency procedures so as to achieve dovetailing between the pipeline emergency procedures and the local authority's emergency plan.

138 The pipeline operator should provide information about the type and consequences of possible major accidents and the likely effects. Information should also be provided on the route of the pipeline, the fluid conveyed and the operating conditions, location of shut-off valves and emergency control arrangements.

139 In the event of an incident involving a pipeline, it is important there is effective communication between the emergency services and pipeline control centre.

25

Guidance

140 The emergency plan should be a written document, in a format which can be used readily in emergencies, and kept up to date to reflect changes in risk, procedures, hardware and personnel. The authors of the plan must address all relevant aspects including the following:

- (a) the types of accidents to people to be taken into account;
- (b) organisations involved including key personnel and responsibilities and liaison arrangements between them;
- (c) communication links including telephones, radios and standby methods;
- (d) special equipment including fire-fighting materials, damage control and repair items;
- (e) technical information such as chemical and physical characteristics and dangers of the fluid conveyed;
- (f) information about the pipeline including route of the pipeline, location of shut-off valves and emergency control arrangements;
- (g) evacuation arrangements;
- (h) contacts and arrangements for obtaining further advice and assistance, eg meteorological information, transport, first aid and hospital services, water and agricultural information;
- (i) arrangements for dealing with the press and other media interests.

141 Since an incident involving a pipeline could occur at any point along its length, it is often inappropriate to provide location specific advice along the whole length of the pipeline. The plan is likely to focus on those parts of the pipeline which are vulnerable to damage such as road, rail and river crossings and other areas of higher risk. Pipeline plans for this reason are likely to be generic and flexible in nature.

142 In discharging their duties, local authorities must take reasonable steps to ensure that they are preparing plans which will prove adequate in the event of major accidents. This will involve checking and testing the various components of each plan during its development.

143 The local authority shall review, and where necessary, revise and update the plan at suitable intervals so that it can be relied upon to work effectively in an emergency. The maximum interval for review should be every three years.

144 For existing pipelines, local authorities are allowed 18 months from notification of the pipeline to prepare the major accident hazard emergency plans (see regulation 27(6)).

145 For all new pipelines, the plan is required before the pipeline is brought into use, or within 9 months of notification of the pipeline to the local authority by HSE, whichever is the later.

Charge by a local authority for a plan

Regulation

Regulation 26

(1) A local authority which prepares, reviews or revises a plan pursuant to paragraph (1) or (3) of regulation 25 may charge a fee, determined in accordance with paragraphs (2) to (4), to the operator of the pipeline to which the plan relates.

(2) A fee shall not exceed the sum of the costs reasonably incurred by the local authority in preparing, reviewing or revising the plan and, where the plan covers pipelines of which there are more than one operator, the fee charged to each operator shall not exceed the proportion of such sum attributable to the part or parts of the plan relating to his pipelines.

(3) In determining the fee no account shall be taken of costs other than the costs of discharging functions in relation to those parts of the plan which relate to the protection of health or safety of persons and which were costs incurred after the coming into force of these Regulations.

(4) The local authority may determine the cost of employing a graded officer for any period on work appropriate to his grade by reference to the average cost to it of employing officers of his grade for that period.

(5) When requiring payment the local authority shall send or give to the operator of the pipeline a detailed statement of the work done and costs incurred including the date of any visit to any place and the period to which the statement relates; and the fee, which shall be recoverable only as a civil debt, shall become payable one month after the statement has been sent or given.

26

Guidance

146 This regulation enables the local authorities who are responsible for preparing and keeping up-to-date emergency plans required under regulation 25 to recover the cost of undertaking this work from the pipeline operator.

147 The local authority may only recover costs that have been reasonably incurred. There may be locations where several pipelines are co-located, so the local authority may decide to prepare one emergency plan covering all the pipelines. In such an event each pipeline operator should be charged for only that part of the costs which can be attributed to the pipeline under his control.

148 The charge made may only be for the cost of preparing the plan itself and of any changes necessary to keep it up to date. It does not cover the cost of emergency equipment (eg fire appliances) considered necessary for the operation of the plan. Furthermore, the charge should relate only to those parts of the emergency plan concerned with the health and safety of people, not with environmental damage.

149 The charge made may be based on the time spent by officers of appropriate grades. The average costs of their employment overheads as well as salary may be taken into account.

26

Guidance

26

150 In presenting a charge to a pipeline operator, the local authority should provide an itemised, detailed statement of work done and cost incurred. Any dispute arising over the charge has to be decided in the civil courts. HSE has no enforcement role for the recovery of cost incurred by a local authority in respect of emergency planning.

Transitional provision

Regulation

27

Regulation 27

(1) In the case of a pipeline, the construction of which is commenced within 6 months after the coming into force of these Regulations, it shall be sufficient compliance with regulation 20 if the particulars specified in Schedule 4 are notified to the Executive within 3 months after the coming into force of these Regulations.

Guidance

27

151 For major accident hazard pipelines where the construction is commenced within 6 months of these Regulations coming into force, the information required in regulation 20 and Schedule 4 should be notified to HSE within 3 months.

Regulation

27

(2) Subject to paragraph (3), in the case of a major accident hazard pipeline, the construction of which was commenced (and whether or not completed) before the coming into force (if these Regulations the particulars specified in Schedule 4 (or, in the case of paragraphs 3, 4, 5, 6 and 8 particulars, where appropriate, of the actual route of the pipeline or of the riser, materials used, fluid conveyed, and the temperature and pressure, and maximum rate of flow of that fluid) shall be notified to the Executive within 6 months after such coming into force.

(3) Paragraph (2) shall have effect where, pursuant to regulation 3(1) of the Notification of Installations Handling Hazardous Substances Regulations 1982^(a), the particulars relating to that pipeline specified in Part II of Schedule 2 to those Regulations have been supplied before such coming into force.

(a) SI 1982/1357

Guidance

27

152 For existing major accident hazard pipelines, or ones under construction, the information required by regulation 18 of Schedule 4 should be notified to HSE within 6 months of the Regulations coming into force, unless the pipeline has been notified to HSE through the notification requirement in the Notification of Installations Handling Hazardous Substances Regulations 1982.

Regulation

27

(4) In the case of a pipeline, the design of which was completed before the coming into force of these Regulations, or within 12 months after such coming into force, regulation 23 shall have effect as if, for the words "before the design of a major accident hazard pipeline is completed" in paragraph (1) of that regulation there were substituted the words "within 12 months after the coming into force of these Regulations".

Guidance

27

153 Where a major accident prevention document (regulation 23) is required for existing major accident hazard pipelines and for proposed new pipelines, where the concept design will be completed within 12 months of the Regulations coming into force, the MAPD should be in place by 11 April 1997.

Regulation

27

(5) *In the case of a pipeline which was first used before the coming into force of these Regulations it shall be sufficient compliance with the requirement in regulation 24(1) where the matters referred to therein are recorded within 6 months after the coming into force of these Regulations.*

Guidance
27

154 For existing major accident hazard pipelines, the emergency procedures should be in place within 6 months of the Regulations coming into force.

Regulation

27

(6) *Where a local authority receives a notification referred to in paragraph (1) of regulation 25 within 6 months after the coming into force of these Regulations, that regulation shall have effect in relation to the pipeline notified as if the reference in that paragraph to 9 months were a reference to 18 months.*

Guidance
27

155 For existing pipelines a local authority, once notified of a major accident hazard pipeline, is allowed 18 months to prepare its emergency plan.

Part IV Miscellaneous

Defence

Regulation

28

Regulation 28

(1) *In any proceedings for an offence for a contravention of any of the provisions of these Regulations it shall, subject to paragraphs (2) and (3), be a defence for the person charged to prove -*

- (a) *that the commission of the offence was due to the act or default of another person not being one of his employees (hereinafter called "the other person"); and*
- (b) *that he took all reasonable precautions and exercised all due diligence to avoid the commission of the offence.*

(2) *The person charged shall not, without leave of the court, be entitled to rely on the defence in paragraph (1) unless, within a period ending seven clear days -*

- (a) *before the hearing to determine mode of trial, where the proceedings are in England or Wales; or*
- (b) *before the trial, where the proceedings are in Scotland,*

he has served on the prosecutor a notice in writing giving such information identifying or assisting in the identification of the other person as was then in his possession.

(3) *For the purpose of enabling the other person to be charged with and convicted of the offence by virtue of section 36 of the 1974 Act, a person who establishes a defence under this regulation shall nevertheless be treated for the purposes of that section as having committed the offence.*

Guidance

28

156 It shall be the operator's responsibility to ensure that any other person contracted to perform work does what is required in helping to meet the legal obligation set by these Regulations. The operator will therefore need to put in place suitable arrangements to ensure proper performance of functions required under these Regulations. Regulation 28(1) offers a defence in legal proceedings, if it can be shown that a contravention of the Regulations is due to an act or default of another person and the operator exercised all due diligence. It should be noted that where the commission of an offence is due to the act or default of another person, HSE has powers, through section 36 of the Health and Safety at Work etc Act 1974 (HSW Act), to prosecute the other person.

Certificates of exemption

Regulation

29

Regulation 29

(1) Subject to paragraph (2) and to any of the provisions imposed by the Communities in respect of the encouragement of improvements in the safety and health of workers at work, the Executive may, by a certificate in writing, exempt any person, pipeline or class of persons or pipelines from any requirement or prohibition imposed by these Regulations and any such exemption may be granted subject to conditions and with or without limit of time and may be revoked by a certificate in writing at any time.

(2) The Executive shall not grant any such exemption unless, having regard to the circumstances of the case and, in particular, to -

- (a) the conditions, if any, which it proposes to attach to the exemption; and*
- (b) any other requirements imposed by or under any enactments which apply to the case,*

it is satisfied that the health and safety of persons who are likely to be affected by the exemption will not be prejudiced in consequence of it.

Repeal of provisions of the Pipe-lines Act 1962

Regulation

30

Regulation 30

Sections 20 to 26, 27 to 32 and 42 of the Pipe-lines Act 1962 are hereby repealed.

(a) 1962 c.58; section 24 was repealed by SI 1974/1986; and section 26A was inserted by section 26 of the Petroleum Act 1987 (1987 c.12).

Guidance

30

157 This regulation sets out the sections of the Pipelines Act 1962 (PA62) which are repealed by these Regulations. These sections are relevant statutory provisions of the HSW Act. Safety notices served by HSE under PA62 do not apply after these Regulations come into force.

158 Section 37 of PA62 which requires notifications of certain pipeline accidents to the emergency services etc. is not being repealed by these regulations since this section covers notifications which may include environmental effects such as pollution of water.

Revocation and modification of instruments

Regulation

31

Regulation 31

(1) The instruments specified in column 1 of Part I of Schedule 6 shall be revoked to the extent specified in column 3 of that Part.

(2) The Notification of Installations Handling Hazardous Substances Regulations ("the 1982 Regulations") shall have effect subject to the modifications of those Regulations specified in Part II of Schedule 6.

Guidance

31

159 This regulation sets out the revocations and modification of statutory instruments associated with these Regulations and also listed in Schedule 6.

160 The Notification of Installations Handling Hazardous Substances Regulations 1982 have been modified to remove the requirement to notify certain pipelines to HSE contained in those Regulations.

Pipelines to which these Regulations do not apply

Schedule

Schedule 1

Regulation 4(2)

- 1 *A pipeline for the conveyance of air, water vapour or steam.*
- 2 *A pipeline for the conveyance of water, other than for the purpose of injecting water into an underwater well or reservoir containing mineral resources.*
- 3 *A pipeline contained wholly within the premises occupied by a single undertaking.*
- 4 *A pipeline which is contained wholly within land which constitutes a railway asset within the meaning of section 6(2) of the Railways Act 1993^(a).*
- 5 *A pipeline contained wholly within a caravan site.*
- 6 *In this Schedule “caravan” and “caravan site” have the same meaning as they have in Part I of the Caravan Sites and Control of Development Act 1960^(b).*

(a) 1993 c. 43.

(b) 1960 c. 62; the meaning of “caravan” in Part I was modified by the Caravan Sites Act 1968 (c.52), section 13(1) and (2).

1

Guidance

161 This Schedule sets out pipelines to which the Regulations do not apply. Pipelines wholly within premises are excluded from the scope of these Regulations.

162 These Regulations do not apply to pipelines contained wholly within caravan sites. In general the pipelines excluded by this paragraph will be LPG gas pipelines which convey gas from a gas tank situated in the caravan site to caravans on the site.

163 Pipelines used as part of the railway infrastructure are also excluded from the scope of these Regulations. However, this exclusion only applies to pipelines used as part of the railway infrastructure; other pipelines on railway land, not forming part of the railway infrastructure, come within the scope of these Regulations.

164 Pipelines which convey water are excluded from the scope of these Regulations except offshore where they convey water for high pressure water injection purposes.

Schedule 1

Descriptions of dangerous fluids

Schedule

Schedule 2

Regulations 18(2) and 27(3)

1 A fluid which -

- (a) is flammable in air;
- (b) has a boiling point below 5°C, at 1 bar absolute; and
- (c) is or is to be conveyed in the pipeline as a liquid.

2 A fluid which is flammable in air and is or is to be conveyed in the pipeline as a gas at above 8 bar absolute.

3 A liquid which has a vapour pressure greater than 1.5 bar absolute when in equilibrium with its vapour at either the actual temperature of the liquid or at 20°C.

4 A toxic or very toxic fluid which -

- (a) is a gas at 20°C and 1 bar absolute; and
- (b) is, or is to be, conveyed as a liquid or a gas.

5 A toxic fluid which -

- (a) at 20°C has a saturated vapour pressure greater than 0.4 bar; and
- (b) is, or is to be, conveyed in the pipeline as a liquid.

6 Acrylonitrile.

7 A very toxic fluid which -

- (a) at 20°C has a saturated vapour pressure greater than 0.001 bar; or
- (b) is, or is to be, conveyed in the pipeline as a liquid at a pressure greater than 4.5 bar absolute.

8 An oxidising fluid which is, or is to be, conveyed as a liquid.

9 A fluid which reacts violently with water.

10 For the purposes of this Schedule -

- (a) a liquid is oxidising; and
- (b) a fluid is toxic or very toxic, or reacts violently with water,

if it has been, or is liable to be classified, pursuant to regulation 5 of the Chemicals (Hazard Information and Packaging for Supply) Regulations 1994^(a), as the case may be, oxidising, toxic, very toxic or reacts violently with water.

2

(a) SI 1994/3247.

Guidance

Schedule 2

165 This Schedule sets out the dangerous fluids which determine the application of the more stringent additional duty requirements of regulations 19 to 27. These duties apply to pipelines conveying fluids in such conditions which are considered to have the potential to cause a major accident (as referred to in regulation 18).

Guidance

166 In general the Schedule applies generic categories for the application of the Regulations. This Schedule lists the categories of fluids and, where appropriate, the conditions and pressures under which they are transported. It is not considered appropriate to include the concept of qualifying quantities for a pipeline.

167 Paragraph 1 of Schedule 2 covers liquefied gases which are flammable in air when they are conveyed as a liquid. This includes butane and propane when conveyed in a pipeline as a liquid.

168 Paragraph 2 of Schedule 2 is applicable to flammable gases conveyed as a gas. In such cases the additional duties only apply when the flammable gas is conveyed at a pressure in excess of 8 bar absolute. This covers such fluids as methane, butane and propane when conveyed as a gas.

169 Mixtures of gas and liquid which have a vapour pressure in excess of 0.5 bar above atmospheric pressure when in equilibrium with its vapour are included. The intention is that this will cover pipelines conveying spiked crude which could have a considerable vapour pressure associated with it as well as pipelines which could be conveying fluids with a presence of sour gases. To determine whether the fluid attracts the additional duties, it is necessary to establish whether the gaseous element will separate out from the liquid with time to produce a pressure in excess of 1.5 bar absolute. The definition thus excludes stabilised crude oils in which the vapour pressure of the dissolved gas is suppressed by the lower vapour pressure of other constituents.

170 Acrylonitrile when conveyed in a pipeline is deemed by these Regulations to be a dangerous fluid. Although only classified by regulation 5 in the Chemicals (Hazard Information and Packaging for Supply) Regulations 1994 (CHIP 2) as toxic, it has the potential to cause a major accident hazard and therefore the requirements of regulations 19 to 27 apply to pipelines conveying this fluid.

171 For the purposes of these Regulations, the categorisations of oxidising, toxic, very toxic or reacts violently with water are derived from regulation 5 in the Chemicals (Hazard Information and Packaging for Supply) Regulations 1994 (CHIP 2).

172 Toxic and very toxic gases when conveyed either as a liquid or a gas will attract the additional duties. This covers pipelines conveying ammonia, bromine, chlorine etc.

173 Toxic liquids pipelines are only considered to possess a major accident potential when the substance is sufficiently volatile. For this reason, only toxic liquids conveyed in a pipeline as a liquid with a saturated vapour pressure in excess of 0.4 bar absolute will attract the additional duties.

174 Very toxic liquids are similarly only considered to possess a major accident potential when either the liquid is sufficiently volatile or when the liquid is conveyed in the pipeline above a certain pressure. For instance, a fluid such as phenol is not sufficiently volatile to attract the additional duties unless conveyed at a pressure in excess of 4.5 bar absolute. Above this pressure it is likely that the liquid will be pumped rather than conveyed under a padding pressure.

175 Fluids classified as oxidising are considered to have a major hazard potential but only when conveyed as liquid. This would cover organic peroxides but would exclude gaseous oxygen.

Schedule 2

Guidance

Schedule 2

176 Other fluids which are considered to have the potential to cause a major accident hazard are substances which are assigned the risk phrase 14 'reacts violently with water'. This generic category covers substances such as oleum and acid chlorides such as chlorosulphonic acids.

Requirements for emergency shut-down valves on certain major accident hazard pipelines connected to offshore installations

Schedule

Schedule 3

Regulation 19

1 An emergency shut-down valve shall be incorporated in the riser of a pipeline -

- (a) in a position in which it can be safety inspected, maintained and tested; and
- (b) so far as is consistent with sub-paragraph (a), as far down the riser as is reasonably practicable;

and such valve shall comply with the remaining paragraphs of this Schedule.

2 An emergency shut-down valve shall be held open by an electrical, hydraulic or other signal to the mechanism for actuating the valve on the failure of which signal the valve shall automatically close.

3 An emergency shut-down valve shall also be capable of being closed -

- (a) by a person positioned by it; and
- (b) automatically by the operation of the emergency shut-down system of the offshore installation to which the pipeline is connected,

or, while relevant work of examination or maintenance is being carried out, by one of those means.

4 If the pipeline is designed to allow for the passage of equipment for inspecting, maintaining or testing the pipeline, the emergency shut-down valve shall also be designed to allow for such passage.

5 An emergency shut-down valve and its actuating mechanism shall so far as is reasonably practicable be protected from damage arising from fire, explosion or impact.

6 An emergency shut-down valve shall be maintained in an efficient state, in efficient working order and in good repair.

Schedule

3

7 After an emergency shut-down valve has operated so as to block the flow of fluid within the pipeline it shall not be re-opened so as to permit the flow of fluid until steps have been taken to ensure that it is safe to do so.

9 In this Schedule “emergency shut-down system” means the system comprising mechanical, electrical, electronic, pneumatic, hydraulic or other arrangements by which the plant on an offshore installation is automatically shut down in the event of an emergency.

Guidance

177 This Schedule sets out the requirements for emergency shut-down valves (ESDVs) on risers which are part of major accident hazard pipelines of 40 mm or more internal diameter at offshore installations under regulation 19.

178 This Schedule requires every riser of 40 mm or more internal diameter which forms part of a major accident hazard pipeline be fitted with an emergency shut-down valve and that the valve is maintained in good working order.

179 The ESDV should be located so that the distance along the riser between the valve and the base of the riser is as low as reasonably practicable, in order that the most vulnerable section of the riser can be isolated from the majority of the pipeline inventory. However, it is equally important that the ESDV can be safely maintained and tested so that it can function properly. It follows that it is important to locate the ESDV above the highest wave crest which can reasonably be anticipated so that the valve can be tested and maintained.

180 Where flexible risers are used, the ESDV should be located on the in-board side of the quick connect/disconnect couplings (QCDC), if fitted, and above the highest wave crest which can reasonably be anticipated.

181 The ESDV location, design, testing, maintenance and operation should ensure that the ESDV will at all times operate on demand or fail-safe in the closed position, so minimising the possibility of an uncontrolled release of the pipeline inventory. Once closed the ESDV should not be reopened until the safety of the installation and connected installations is assured.

182 The ESDV should be capable of stopping the flow of the fluid within the pipeline. However, this disregards minor leakage past the ESDV which cannot represent a threat to safety. The operator should make an assessment of the maximum internal rate that can be tolerated. The rate of leakage should be based on the installation’s ability to control safely the hazards produced by such a leak.

183 ESDVs should be rapid-acting isolation valves, capable of being operated remotely by the operation of the associated installation’s emergency shut-down system or locally by a person positioned by it.

184 Where maintenance or examination of the ESDV is being carried out which involves disabling one of the two actuation systems while the work is being undertaken, this is permissible provided that once the work is completed both the actuating mechanisms are returned to full working order.

185 If the pipeline of which the riser forms part has been designed to allow the passage of equipment, such as pigs for inspection etc, the ESDV should be designed to allow the passage of that equipment. For example, in the case of a piggable pipeline system, the ESDV should also be piggable and therefore a ball or gate valve is likely to be used.

Schedule 3

Guidance

186 The valve and its actuating mechanism are required to be protected, so far as is reasonably practicable, against fire, explosion and impact. The aim is that, under all foreseeable conditions, the ESDV should be capable of closing fail-safe. The extent of the protection system should at least cover the ESDV, its actuator and any components required for fail-safe closure of the valve.

187 In order to define the type and extent of fire protection required the operator will need to consider the type, severity and duration of anticipated fires as well as the minimum duration for which the integrity and operability of equipment to be protected must be maintained.

188 It is not usually reasonably practicable to afford protection against all the effects of an explosion in the immediate vicinity of an ESDV. In general explosion protection is best achieved by locating the ESDV well outside congested equipment modules.

Relationship with other Regulations

189 Regulation 5 of the Offshore Installations (Prevention of Fire and Explosion, and Emergency Response) Regulations 1995 (PFEER) requires the owner or operator of an installation to carry out an assessment of the major accident hazards involving fire or explosion, and to identify appropriate arrangements to deal with them. The information about major accident hazards and the measures taken to reduce risks in this regulation can be used to demonstrate that the ESDV is capable of adequately blocking the flow of fluid within the pipeline riser in the Pipelines Safety Regulations 1996.

Schedule 3

Particulars to be included in notification relating to construction of a major accident hazard pipeline

Schedule

Schedule 4

Regulations 20 and 27(1) and (2)

- 1 *The name and address of the operator of the pipeline.*
- 2 *The proposed route of the pipeline in the form of maps or drawings.*
- 3 *The proposed route of the riser on any offshore installation, in the form of drawings.*
- 4 *The length, diameter and wall thickness of the pipeline.*
- 5 *The materials to be used in the construction of the pipeline.*
- 6 *The fluid to be conveyed and such of its properties as are relevant to health and safety.*

4

Schedule

4

7 *The safe operating limits of the pipeline.*

8 *The intended temperature, pressure, and maximum rate of flow of the fluid to be conveyed.*

Guidance

190 This Schedule sets out the information to be included under regulation 20. This notification may form the first contact between the pipeline operator and HSE; earlier contact may be helpful. This 'end of concept design' notification should be made at a point where the design is sufficiently well enough advanced to be able to set out, in general terms, the particulars required in this Schedule but not so late that the company has already committed major expenditure.

191 Only a limited amount of information about the pipeline is required at this notification stage. This notification is aimed at triggering HSE's inspection arrangements and it will provide the basis for the start of a dialogue between the pipeline operator and HSE about arrangements to secure the safety of the pipeline. The intention behind this notification is to ensure that HSE is made aware of the proposed pipeline before major expenditure has been committed, since it is at this early stage that the most recent and best practice of design, and use of materials, can be applied at least cost. Where some of the information cannot, at the time of notification, be fully specified, notification to HSE should go ahead together with details of when the further information may be provided, by agreement between the operator and HSE. The information that is supplied will help HSE to form a view on appropriate inspection arrangements.

192 The information to be supplied need only represent the particulars as far as they have been developed by this stage. It is likely that there may be minor changes to the information, but where the changes are significant to the level of risk of the pipeline, these further details should be supplied to HSE.

Schedule 4

Particulars to be notified before certain events relating to major accident hazard pipelines

Schedule

5

Schedule 5

Regulation 22(2) and (3)

1 *In relation to a change to the route or position of a pipeline, particulars in the form of maps or drawings of the new route or position.*

2 *In relation to a change to the safe operating limits of a pipeline, particulars of such change.*

3 *In relation to the start of major modification or major remedial work to the pipeline, particulars of such work.*

Schedule

5

- 4 *In relation to the conveyance of a new fluid, particulars of -*
- (a) *such of its properties as are relevant to the health or safety of persons; and*
 - (b) *the intended or (if, in a case to which regulation 22(3) applies, conveyance has started) actual temperature, pressure and maximum rate of flow in the pipeline.*
- 5 *In relation to the start of decommissioning or dismantlement of the pipeline, particulars of the steps to be taken or (if, in a case 10 which regulation 22 (3) applies, decommissioning or dismantlement has started) taken in connection with such decommissioning or dismantlement.*

Guidance

193 These notifications concern changes to a major accident hazard pipeline, its operation or environment which may have an effect on the pipeline integrity or level of risk from, or to, that pipeline.

194 This would include prior notification of changes to the position of a pipeline, design intent (including change of use), safe operating regime, end of use or any change in the level of risk for any reason.

195 There is a clear distinction between pipeline works which involve risks to those actually carrying out the work and changes to the pipeline which could affect the level of pipeline risk. These notifications are not intended to include notification of pipeline works.

196 The level of pipeline risk can be affected or altered due to a number changes, some of which are similar to those principal items used at the notification of construction activities:

- route or position;
- service conditions;
- pipeline materials and equipment.

Changes in position or route

197 The proximity of a major accident hazard pipeline relative to occupied buildings or with respect to its position on an offshore installation is a safety critical item and has a significant impact on risk levels. For example, notifications would be required for changes to:

- the route or position of a pipeline, including pipeline diversions because of new developments or encroachments and for tie-ins to new installations, other pipelines, etc;
- the route or position of pipeline risers on offshore installations including diversions to separate riser platforms.

Changes in fluid composition or type

198 If the range of properties of the conveyed fluid is expected to change from those specified or anticipated at the original design stage, then those changes are notifiable. Pipelines may be initially designed to transport one type of substance or fluid, but there may come a time when there is a requirement to use the pipeline for other purposes, eg to change from oil production to water injection (to increase field life), from oil to gas, etc. The composition of a fluid may change significantly during the life of a field development, eg from sweet to sour gas or oil, which may or may not have been taken into account at the initial design stage.

Schedule 5

Guidance

Changes in safe operating limits

199 Changes in the maximum allowable operating pressure (MAOP) of a pipeline, whether temporary or permanent, are notifiable. Where a pipeline MAOP may have to be temporarily or permanently lowered following damage to the pipeline or because of developments in close proximity to the pipeline, this information should be notified to HSE.

200 A pipeline MAOP may need to be raised above the original design pressure in some cases. If this is proposed, it will probably have significant implications on the pipeline integrity and risk levels which must be fully evaluated.

End of use of a pipeline

201 Notification would be required of plans to decommission on a long-term basis, 'moth-ball' or finally decommission a pipeline.

Changes in pipeline materials and equipment

202 Notifications should be made where there are changes to critical dimensions (wall thickness, diameter) of a pipeline such as installation of thicker-walled pipe sections for protection or proximity infringements.

203 Replacement of pipelines or sections of pipelines (eg due to severe damage or corrosion) should be notified where the new material is different from the existing material. Steels of a different standard or strength may have been selected or materials may be changed from 'hard' pipe to flexible or composite pipeline sections (or vice versa).

What is not notifiable?

204 Notification to HSE need not be made for:

- any changes to pipeline not defined as a major accident hazard pipeline, unless that change results in that pipeline falling under the additional duties, eg change of use from conveying a low hazard fluid, such as stabilised crude oil, to an extremely flammable liquid or flammable gas;
- repairs to a pipeline following a reportable dangerous occurrence under the Reporting of Injuries, Diseases and Dangerous Occurrences Regulations 1995 (RIDDOR);
- replacement on a like-for-like basis of components or sections of a pipeline, including flexible riser and pipeline replacement on a planned basis;
- minor adjustments to the pipeline operating system (control systems, leak detection, etc);
- running repairs (slight surface damage repairs, coating and wrapping repairs, rectification of spans, replacement of cathodic protection systems, repairs to protective slabbing or concrete mattresses, etc);
- routine inspection and maintenance work and the results of any surveys and changes to the inspection and maintenance scheme;
- pigging operations both routine and special operations, eg on-line inspection using intelligent pigs;
- retesting of pipelines for leak tightness.

Schedule 5

Revocation and modification

Schedule 6

Schedule 6

Regulation 31

Part I Revocation of instruments

<i>1</i> <i>Title</i>	<i>2</i> <i>Reference</i>	<i>3</i> <i>Extent of revocation</i>
The Gas Safety Regulations 1972	SI 1972/1178	The whole Regulations
The Gas (Metrication) Regulations 1980	SI 1990/1851	Regulation 3(1)
The Submarine Pipe-lines Safety Regulations 1982	SI 1982/1513	The whole Regulations except regulations 1 (1) and 11
The Submarine Pipe-lines Safety (Amendment) Regulations 1986	SI 1986/1985	The whole Regulations
The Offshore Installations (Emergency Pipe-line Valve) Regulations 1989	SI 1989/1029	The whole Regulations
The Submarine Pipe-lines (Inspectors and Safety) (Amendment) Regulations 1991	SI 1991/680	Regulation 3

Part I

Schedule 6

Part II Modification of the Notification of Installations Handling Hazardous Substances Regulations 1982

1 *In the definition of "installation" in paragraph (1) of regulation 2 (interpretation) of the 1982 Regulations the words "or pipe-line" shall be omitted.*

2 *In regulation 3 (notification of installations handling hazardous substances) of the 1982 Regulations -*

(a) *in paragraph (1) the words -*

(i) *"or in any pipe-line to which paragraph (4) applies"; and*

(ii) *"the appropriate part of" shall be omitted; and*

(b) *paragraph (4) shall be revoked.*

3 *In regulation 4 (updating of the notification following changes in the notifiable activity) of the 1982 Regulations the words "or in the pipe-line" shall be omitted.*

4 *In regulation 5 (re-notification where the quantity of a substance is increased to 3 times that already notified) of the 1982 Regulations the words "of Part I" shall be omitted.*

Part II

Schedule 6

Part II

- 5 *In Schedule 2 of the 1982 Regulations -*
- (a) the title "Part I" shall be omitted; and*
 - (b) Part II shall be revoked.*

Further information

HSE priced and free publications can be viewed online or ordered from www.hse.gov.uk or contact HSE Books, PO Box 1999, Sudbury, Suffolk CO10 2WA Tel: 01787 881165 Fax: 01787 313995. HSE priced publications are also available from bookshops.

For information about health and safety ring HSE's Infoline Tel: 0845 345 0055 Fax: 0845 408 9566 Textphone: 0845 408 9577 e-mail: hse.infoline@natbrit.com or write to HSE Information Services, Caerphilly Business Park, Caerphilly CF83 3GG.

British Standards can be obtained in PDF or hard copy formats from BSI: <http://shop.bsigroup.com> or by contacting BSI Customer Services for hard copies only Tel: 020 8996 9001 e-mail: cservices@bsigroup.com.