

# Trailer Action

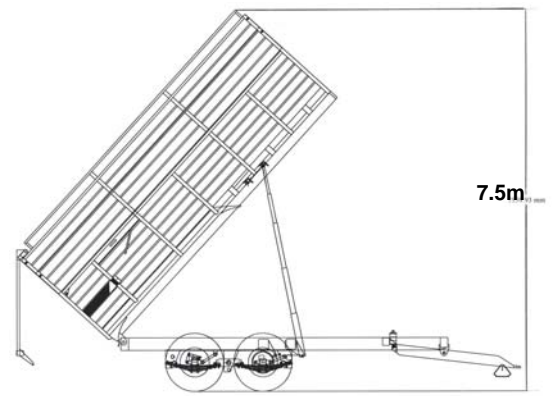

## Things you need to know before you go

- The length, width and height of the trailer.
- The turning circle of the combination.
- The overall height when tipped.
- The size of tractor needed with the correct hitch.



Check drawbar rings for wear



Check wheel nuts regularly

## Things to check before you move

- Tyres in good condition and at the correct pressures.
- Wheel nuts tight.
- Hitch hook ring and trailer ring checked for wear.
- Braking system and tyres to suit the tractor road speed.

## Coupling Up

- Trailer parking brake firmly "ON" or the wheels chocked.
- Pick-up hitch properly latched.
- Brake line hose and lighting cable connected – check both systems for operation.
- Lighting cable connected.
- Tractor mirrors clean and adjusted.
- Lift arms positioned above the draw bar.



Protect the hoses and cables

## Before Driving

- Consider if you have the knowledge and experience to operate the combination safely or if you need more training or supervision.
- Have the correct licence and insurance.

## On the Road

- Know the rules of the road.
- Drive safely for the conditions – think ahead to make best use of engine, braking, transmission shifting and lastly brakes for smooth control.
- "Be Seen" – Keep the lights clean and in good condition – switch them on during dull or wet weather.
- Give early indication before turning.
- Keep the lights and number plate clean.

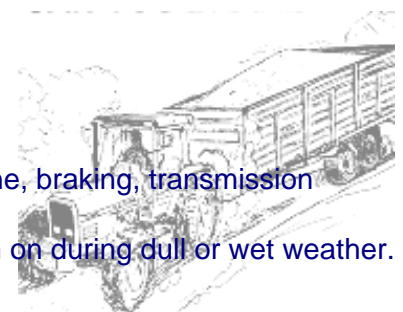

## In the Field

- Plan your route and treat slopes with respect.
- Do not overload.
- Load the trailer evenly and securely.
- Attach straps or ropes only to secure lashing points.
- Look out for changing conditions.

**REMEMBER** – It is illegal to carry a child of less than 13 years on a tractor or agricultural machine.



Tel: 028 9037 0713  
www.yfcu.org



Tel: 0800 0320 121  
www.hseni.gov.uk



Tel: 028 9756 2949

## In the Yard

- When reversing:
  - Check the area in advance.
  - Look out for children.
  - Keep any helper within view.
  - Do not permit anyone to stand behind.
- When tipping:
  - Only tip on firm level ground.
  - Check when tipping grass at the rear, door is released on both sides (non-KANE makes).
  - Always return the trailer body to its lowered position before moving off.
  - Look up for overhead power lines, obstructions or items that could fall.



**A safe play area for children**

***If the trailer makes contact or comes close to live power cables, try to lower the body and drive away. If you have to leave the combination in position and get out of the cab – JUMP WELL CLEAR – DO NOT TOUCH THE VEHICLE AND THE GROUND AT THE SAME TIME.***



## Parking an Unhitched Trailer.

- Only park on level ground off the public road.
- Apply the parking brake firmly or chock the wheels.



## If you get a puncture on the road

- Try to pull off the carriageway onto firm ground.
- Otherwise make the trailer as visible as possible by switching on the hazard warning lights.
- If jacking the trailer, make sure that it is well supported and cannot roll forward.
- Tighten the wheel nuts fully when the wheel is refitted and check them frequently.

## During maintenance work

- Keep clear of the unpropped body – do not rely on hydraulics alone – use a mechanical prop.
- Do not place your hand near even the smallest of high pressure hydraulic leaks.

**If oil penetrates the skin go to the nearest accident and emergency unit  
Immediately for medical attention.**

